



Installation Operation Maintenance

Voyager™ II Rooftop units

Cooling-only

TKD-TKH 155-175-200-250-265-290-340

Heat pump

WKD-WKH 125-155-200-265-290-340

Cooling-only with gas-fired heating

YKD-YKH 155-175-200-250

Heat pump with gas-fired heating

DKD/DKH 125-155-200-265-290-340

R410A Refrigerant





Table of Contents

General information	4
Foreword	4
Warnings and cautions.....	4
Safety recommendations.....	4
Reception.....	4
Warranty	4
Maintenance contract.....	5
Storage	5
Training.....	5
Installation	6
Reception of units	6
Roof curb installation	7
Dimensions/Weights/Clearances	8
Installing the unit.....	11
Connection of duct network.....	12
Condensate drain piping.....	13
Energy Recovery Module	13
Gas pipework installation	14
Filter installation	15
Supply fan adjustment.....	25
Supply fan performances.....	25
Component air pressure drops.....	27
Electrical connection	28
Controls	30
Control wiring	30
CO ₂ sensors	32
Remote potentiometer	34
Fire thermostat.....	35
Clogged filter detector.....	36
Smoke detector.....	36
High temperature safety thermostat.....	36
Remote fault relay	36
Thermostats	36
Communication Interfaces.....	37

Table of Contents

Unit Options.....	38
Hot water coil	38
Electric Heater	39
Soft Starter	39
80 - 100% Supply fan Frequency Inverter	40
0 - 25% fresh air hood	43
Barometric relief	43
Energy Recovery module	43
Exhaust fan.....	44
Operation	45
Operation with a conventional thermostat.....	45
Setting the economizer	47
Test procedures.....	48
Test modes	49
Unit start-up	50
Cooling without an Economizer	54
Low Ambient Operation.....	54
Cooling with an Economizer	54
Economizer Set-Up.....	55
ReliaTel™ Control Heating Operation	55
Ignition Module	55
Final installation checklist	56
Maintenance	57
End user routine maintenance	57
Service technician maintenance.....	57
Troubleshooting.....	58

General information

Foreword

These instructions are given as a guide to good practice in the installation, start-up, operation, and maintenance by the user, of Trane TKD/TKH, WKD/WKH and YKD/YKH, YKD/YKH and DKD/DKH units. They do not contain full service procedures necessary for the continued successful operation of this equipment. The services of a qualified technician should be employed through the medium of a maintenance contract with a reputable service company. Read this manual thoroughly before unit start-up.

TKD/TKH units are designed to operate in cooling mode only, with optional auxiliary heat (electric heater or hot water coil).

WKD/WKH can operate in cooling mode or heating mode by reversing the refrigeration cycle with or without auxiliary heat.

YKD/YKH units are designed to operate in cooling mode and equipped with a gas fired heating module.

DKD/DKH units are designed to operate in cooling mode or heating mode by reversing the refrigeration cycle with a gas fired heating module as auxiliary heat.

TKD/TKH, WKD/WKH, YKD/YKH and DKD/DKH units are assembled, pressure tested, dehydrated, charged and run tested before shipment.

Warnings and cautions

Warnings and Cautions appear at appropriate sections throughout this manual. Your personal safety and the proper operation of this machine require that you follow them carefully. The constructor assumes no liability for installations or servicing performed by unqualified personnel.

WARNING! : Indicates a potentially hazardous situation which, if not avoided, could result in death or serious injury.

CAUTION! : Indicates a potentially hazardous situation which, if not avoided, may result in minor or moderate injury. It may also be used to alert against unsafe practices or for equipment or property-damage-only accidents.

WARNING R-410A!

Refrigerant under higher pressure than R-407C!

The unit described in this manual uses R-410A refrigerant which operates at higher pressures than R-407C refrigerant. Use R-410A ONLY rated service equipment or components with this unit. For specific handling concerns with

R-410A, please contact your local Trane representative. Failure to use R-410A rated service equipment or components could cause equipment or components explosion under

R-410A high pressures that could result in death, serious injury, or equipment damage.

Safety recommendations

To avoid death, injury, equipment or property damage, the following recommendations should be observed during maintenance and service visits:

1. The maximum allowable pressures for system leak testing on low and high pressure side are given in the chapter "Installation". Always provide a pressure regulator.
2. Disconnect the main power supply before any servicing on the unit.
3. Service work on the refrigeration system and the electrical system should be carried out only by qualified and experienced personnel.

Reception

On arrival, inspect the unit before signing the delivery note.

In case of visible damage: The consignee (or the site representative) must specify any damage on the delivery note, legibly sign and date the delivery note, and the truck driver must countersign it. The consignee (or the site representative) must notify Trane Epinal Operations - Claims team and send a copy of the delivery note. The customer (or the site representative) should send a registered letter to the last carrier within 3 days of delivery.

Reception in France only:

Concealed damage must be looked for at delivery and immediately treated as visible damage.

Reception in all countries except France:

In case of concealed damage: The consignee (or the site representative) must send a registered letter to the last carrier within 7 days of delivery, claiming for the described damage. A copy of this letter must be sent to Trane Epinal Operations - Claims team.

Warranty

Warranty is based on the general terms and conditions of the manufacturer. The warranty is void if the equipment is repaired or modified without the written approval of the manufacturer, if the operating limits are exceeded or if the control system or the electrical wiring is modified. Damage due to misuse, lack of maintenance or failure to comply with the manufacturer's instructions or recommendations is not covered by the warranty obligation. If the user does not conform to the rules of this manual, it may entail cancellation of warranty and liabilities by the manufacturer.

General information

Maintenance contract

It is strongly recommended that you sign a maintenance contract with your local Service Agency. This contract provides regular maintenance of your installation by a specialist in our equipment. Regular maintenance ensures that any malfunction is detected and corrected in good time and minimizes the possibility that serious damage will occur. Finally, regular maintenance ensures the maximum operating life of your equipment. We would remind you that failure to respect these installation and maintenance instructions may result in immediate cancellation of the warranty.

Storage

If the unit is to be stored for more than one month prior to installation, observe the following precautions:

- Units charged with refrigerant should not be stored where temperatures exceed 68°C.
- At least every three months, use a gauge to manually check the pressure in the refrigerant circuit. If the refrigerant pressure is below 13 bar at 20°C (or 10 bar at 10°C), call a qualified service organization and the appropriate Trane sales office.

Take precautions to prevent condensate formation inside the unit's electrical components and motors when:

1. The unit is stored before it is installed; or,
2. The unit is set on the roof curb and temporary auxiliary heat is provided in the building.

Isolate all side panel service entrances and base pan openings (e.g., conduit holes, S/A and R/A openings, and flue openings) to minimize ambient air from entering the unit until it is ready for start-up.

Do not use the unit's heater as temporary heat without completing the start-up procedures detailed under "Unit Start-Up."

The Trane Company will not assume responsibility for equipment damage resulting from accumulation of condensate on the unit electrical components.

Training

To assist you in obtaining the best use of it and maintaining it in perfect operating condition over a long period of time, the manufacturer has at your disposal a refrigeration and air conditioning service school. The principal aim of this is to give operators and technicians a better knowledge of the equipment they are using, or that is under their charge. Emphasis is particularly given to the importance of periodic checks on the unit operating parameters as well as on preventive maintenance, which reduces the cost of owning the unit by avoiding serious and costly breakdown.

Installation

General information : The installation must conform to all local standards and regulations.

Reception of units

Rooftop unit

The unit is supplied on a wooden frame. It is recommended to check the machine's condition upon reception.

There are two ways to handle the unit:

1. Use the openings in the wooden frame to handle the machine using a fork lift, in accordance with applicable safety regulations.
2. Use a lifting beam correctly adjusted to fit the unit (Figure 1a).

Unit handling

The units are supplied on the truck but are not unloaded. An opening is provided on each corner of the unit base to facilitate handling. 4 shackles and 4 slings are required. Use a lifting beam to prevent the cables pressing too hard on top of the unit during lifting.

Figure 1a indicates the position of the center of gravity and the lifting recommendations.

Important: For unit to fit on the roof curb the fork lift pockets must be removed.

Figure 1a - Unit handling

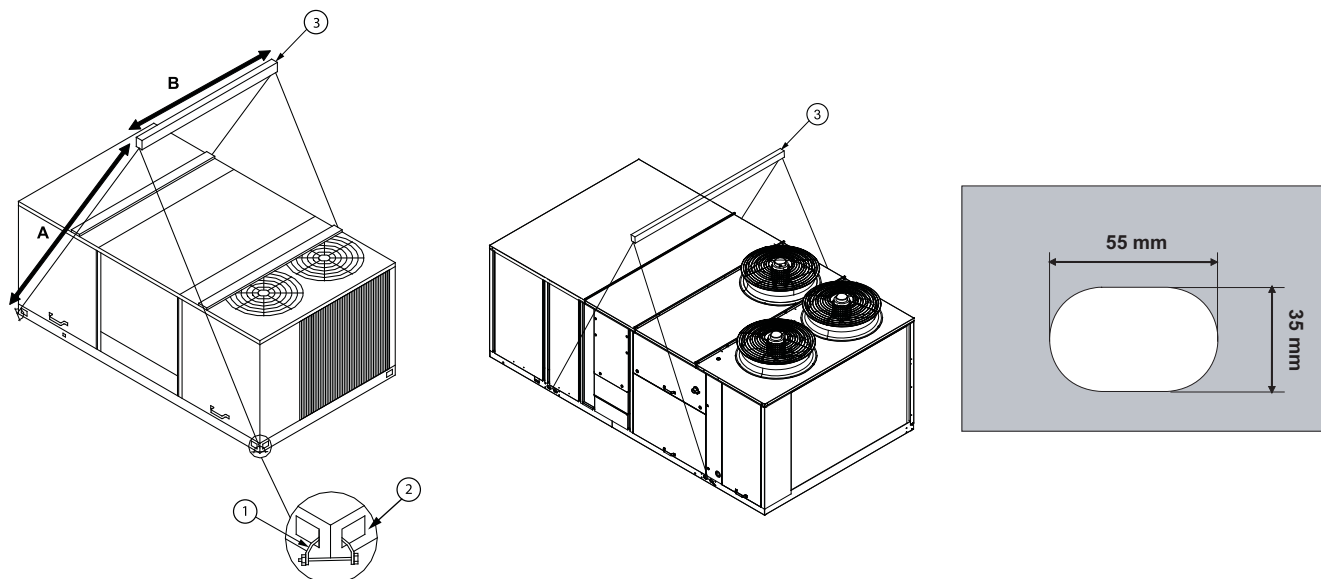

- 1 = Clevis
- 2 = Base Rail
- 3 = Spreader Bar

Refer to Tables 3a and 3b for weights and center of gravity.

Installation

Roof curb Installation (TKD-WKD-YKD accessories)

Roof curbs are available as an accessory for “downflow” units to support the unit and ensure the water tightness between the rooftop and the roof. Two types of roof curbs are available: The standard version to allow the installation of the unit on a flat roof and the adjustable version for a sloped roof installation. (See Figure 1b for the maximum slope correction of adjustable roof curb.)

The adjustable roof curbs are supplied pre-assembled on a skid.

Two types of self-adhesive seals are provided separately. (40 mm wide for the perimeter, 20 mm wide for the cross pieces). Make sure they are properly installed where indicated to assure an adequate curb to unit seal.

Instructions for the roof curb assembly and installation with curb dimensions are provided with each roof curb kit.

Table 1 - Sling lengths and maximum unit weight

Unit size	A	B	Maximum weight kg
125			747
155	3000	1900	774
175			718
200			881
250			931
265	3500	2200	1033
290			1325
340			1333

Figure 1b - Maximum slope correction of adjustable roof curb.

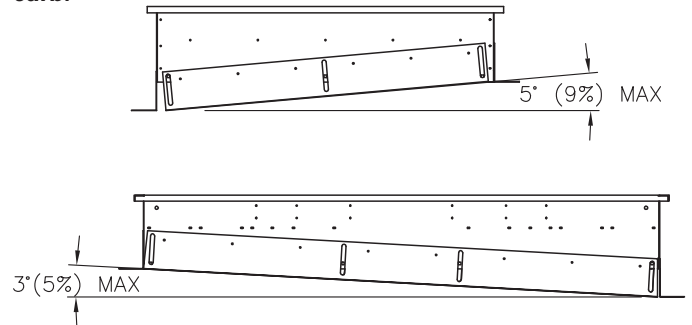
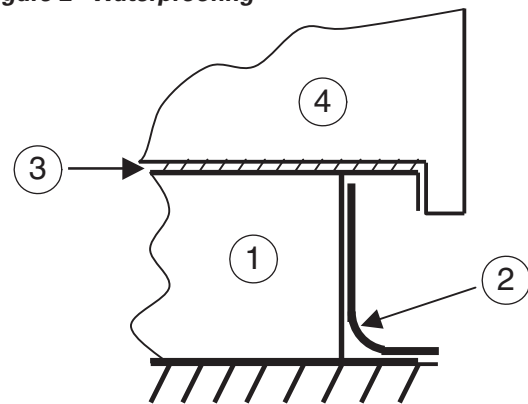

Figure 2 - Waterproofing



- 1 = Roofcurb
- 2 = Roof membrane
- 3 = Seal
- 4 = Rooftop

Installation

Dimensions/Weights/Clearances

Figure 3 - Minimum clearances

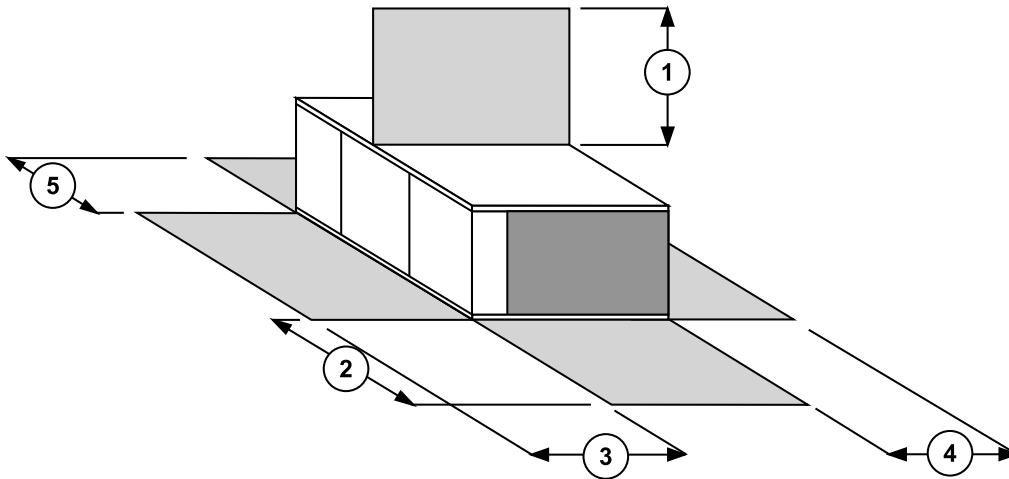

Table 2 - Minimum clearances (mm)

UNIT	Minimum clearances (mm)				
	1	2	3	4	5
TK* / YK* 155	1900	1800	1220	1000	1300
TK* / YK* 175	1900	1800	1220	1000	1300
TK* / YK* 200	1900	1800	1220	1000	1300
TK* / YK* 250	1900	1800	1220	1000	1300
TK* 265	1900	1800	1220	1000	1300
TK* 290	1900	1800	1220	1000	1300
TK* 340	1900	1800	1220	1000	1300
WK* / DK* 125	1900	1800	1220	1000	1300
WK* / DK* 155	1900	1800	1220	1000	1300
WK* / DK* 200	1900	1800	1220	1000	1300
WK* / DK* 265	1900	1800	1220	1000	1300
WK* / DK* 290	1900	1800	1220	1000	1300
WK* / DK* 340	1900	1800	1220	1000	1300

The structure accommodating the unit(s) must be designed to support the equipment in operation, as a minimum. Refer to Table 3.

Installation

Table 3 - Weights & center of gravity (Figure 4)

UNIT	Unit Dimension			Maximum weight		Corner Weight (1)				Center of Gravity	
	X (mm)	Y (mm)	Z (mm)	Net (kg)	Shipping (kg)	A (kg)	B (kg)	C (kg)	D (kg)	Length (mm)	Width (mm)
YKD / YKH 155	2726	1811	1313	673	693	234	170	155	114	1143	737
YKD / YKH 175	2726	1811	1313	706	726	241	181	162	122	1168	737
YKD / YKH 200	3107	2167	1704	847	902	298	223	187	139	1321	838
YKD / YKH 250	3107	2167	1704	869	948	300	231	192	146	1346	838
TKD / TKH 155	2726	1811	1313	598	652	210	153	136	99	1143	711
TKD / TKH 175	2726	1811	1313	631	666	217	164	142	108	1168	711
TKD / TKH 200	3107	2167	1704	768	819	271	202	169	126	1321	838
TKD / TKH 250	3107	2167	1704	789	864	269	206	184	130	1346	838
TKD / TKH 265	3107	2154	1704	869	934	296	227	203	143	1340	921
TKD / TKH 290	3987	2154	1704	1140	1205	337	317	233	253	1910	923
TKD / TKH 340	3987	2154	1704	1148	1213	347	307	227	267	1857	926
WKD / WKH 125	2726	1811	1313	637	685	222	162	146	107	1143	711
WKD / WKH 155	2726	1811	1313	654	707	232	165	150	107	1143	711
WKD / WKH 200	3107	2167	1704	819	890	274	213	187	145	1346	889
WKD / WKH 265	3107	2154	1704	889	954	297	231	203	158	1345	925
WKD / WKH 290	3987	2154	1440	1183	1248	348	329	243	263	1911	926
WKD / WKH 340	3987	2154	1440	1191	1256	355	324	240	272	1859	929
DKD / DKH 125	2726	1811	1313	707	755	246	180	162	119	1143	711
DKD / DKH 155	2726	1811	1313	729	782	259	184	167	119	1143	711
DKD / DKH 200	3107	2167	1704	898	969	300	233	206	159	1346	889
DKD / DKH 265	3107	2154	1704	968	1033	323	251	222	172	1345	925
DKD / DKH 290	3987	2154	1440	1268	1333	373	353	260	282	1911	926
DKD / DKH 340	3987	2154	1440	1276	1341	380	347	258	291	1859	929

1. Corner weights are given for information only. All models must be supported continuously by a curb or equivalent frame support.

Installation

Table 4 - Factory installed options net weights (kg)

UNIT	Standard Roof Curb	Pitched Roof Curb	Economizer	Manual Outside Air Damper	Motorized Outside Air Damper	Electric heater	Hot water coil	Power exhaust fan	Direct drive fan
WKD/DKD 125	93	220	30	15	27	14	85	49	31
WKD/DKD/TKD/YKD 155	93	220	30	15	27	14	85	49	31
TKD/YKD 175	93	220	30	15	27	14	85	49	24
WKD/DKD/TKD/YKD 200	107	260	37	15	34	18	110	49	48
TKD/YKD 250	107	260	37	15	34	18	110	49	53
WKD/DKD/TKD 265	107	260	37	15	34	18	110	49	53
WKD/DKD/TKD 290	107	260	37	15	34	18	110	49	80
WKD/DKD/TKD 340	107	260	37	15	34	18	110	49	80
WKH/DKH 125	—	—	30	15	27	14	—	—	—
WKH/DKH/TKH/YKH 155	—	—	30	15	27	14	—	—	—
TKH/YKH 175	—	—	30	15	27	14	—	—	—
WKH/DKH/TKH/YKH 200	—	—	37	15	34	18	—	—	—
TKH/YKH 250	—	—	37	15	34	18	—	—	—
WKH/DKH/TKH 265	—	—	37	15	34	18	—	—	—
WKH/DKH/TKH 290	—	—	37	15	34	18	—	—	—
WKH/DKH/TKH 340	—	—	37	15	34	18	—	—	—

Notes :

Net weight should be added to unit weight when ordering factory installed accessories.

To estimate shipping weight add 2.3 kg to net weight.

Figure 4

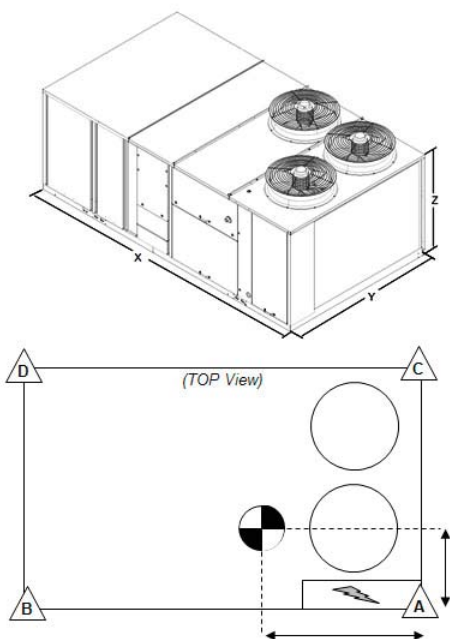

Installing the unit

1) Unit mounting on roof

Fix the rooftop curb on the joint beam of the building's structure. Make the rooftop curb's sealing surface level using angle brackets adjusted by screw bolts, located around its perimeter. Place the adhesive seals on the curb's sealing surface (perimeter and cross pieces). Make the rooftop leak-tight around the curbs before installing the unit, in compliance with current construction standards.

Note: The unit must be installed perfectly level to ensure condensates flow from the condensate tray.

The rooftop unit nests into the curb and is supported by it. Position the unit, taking care to comply with the indicated directions: the unit's discharge and intake openings must match those of the curb.

2) Installing the unit on the ground

To install the unit on the ground, its base must be level and supported securely.

For horizontal discharge units, a support is required such as a metal or concrete slab whose height must be determined according to the amount of snow cover, to prevent problems with condensation drainage and obstruction of the external coil. If necessary use an anti-vibration material between the rooftop unit's base and the support.

Note: Unit installation must comply to local codes

Figure 5a

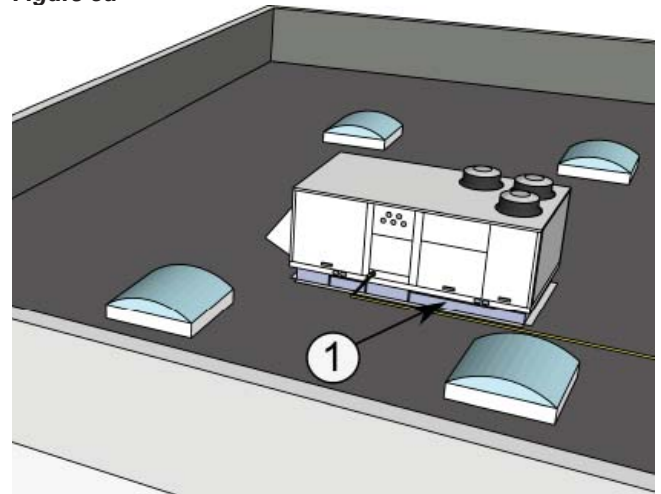

1 = Frame

Figure 5b

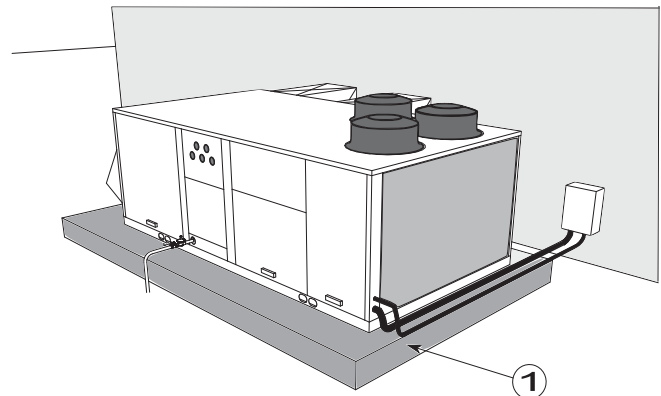

1 = Concrete slab

Installation

Connection of duct network

1) Downflow discharge units (TKD,WKD,YKD, DKD)

Using the rooftop curb

- The rooftop curb must be insulated on the outside walls at the discharge and intake openings to prevent condensation in the ducts.
- The rims around the discharge and intake openings make it possible to attach the flanges on the ends of the ducts. If you are using rigid duct ends recommended on the rooftop curb plan, it is essential to fix these components before installing the unit.
- For the design of the duct network, comply with recommendations currently applicable on the market, in particular:
- Installation of a section of flexible ducts to limit transmission of the unit's vibrations
- Use of movable vanes or deflectors to reduce the sound level.

2) Horizontal discharge units (TKH,WKH,YKH, DKH)

- The intake and discharge ducts must be insulated (thermal insulation).
- The duct section located outside must be leak-tight.
- Provide a flexible connector to prevent transmission of the unit vibrations. This flexible duct must be installed inside the building.

Note: In case of use of TKH, WKH or YKH or DKH units with economizer option, temperature and humidity sensors must be installed in return duct. Economizer linkage is factory mounted but the damper position must be adjusted on site.

Figure 6 - Condensate Drain location

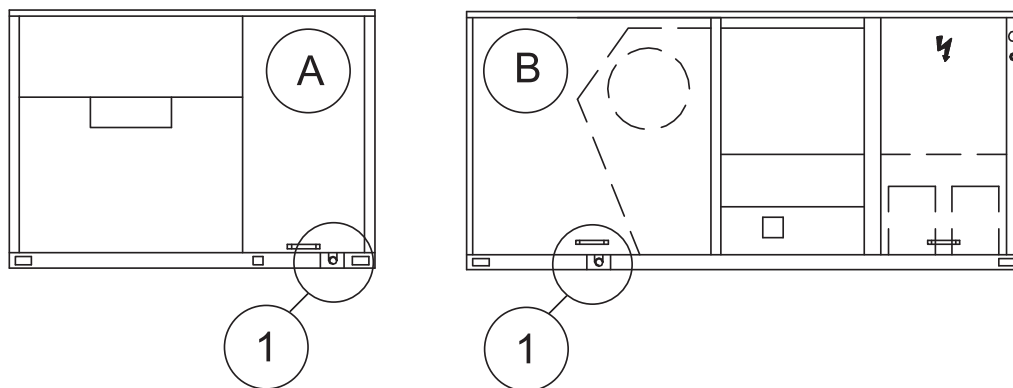

1 = Condensate drain connection

A = TKH / YKH / WKH / DKH

B = TKD / YKD / WKD / DKD

Condensate drain piping

Each Voyager II is equipped with a female threaded connector. A P-trap and a tube extension are provided and must be connected to the drainage as shown in Figure 7.

Slope the drainage pipe down at least 1% to ensure adequate condensate flow.

Check all the condensate drainage pipe fittings comply with the applicable construction regulations and waste disposal standards.

Energy Recovery Module

For the installation of the energy recovery option please refer to document RT-SVX42 delivered with the unit.

Figure 7 - Condensate drain line connection

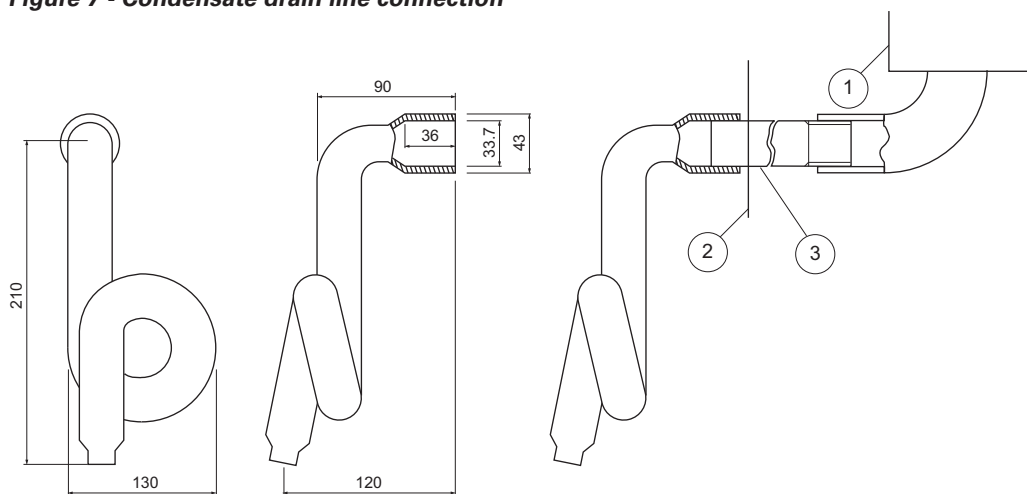

1 = Static pressure drain pan

2 = Panel enclosure

3 = Tube extension

Installation

Gas pipework installation

The installation must conform to all standards and regulations.

The gas supply pipework and gas stop valve to be installed near the unit must be sized so as to assure the gas pressure is sufficient at the unit inlet when operating at full load.

CAUTION! Should the pressure at the unit valve gas inlet be higher than 0.035 bar, an expansion valve must be installed.

The pipework must be self-supporting and the final connection to the burner must be made by a flexible pipe. Provide a dust protection (filter) upstream the unit connection.

CAUTION! The gas pipework must not exert any stress on the burner gas connection.

Note: Expansion valve must be adapted to the type of gas used:

- G 20: 20 mb
- G 25: 25 mb
- G 31: (Propane): 37 or 50 mb

See burner performance table.

Gas leak check procedure

1. Vent the gas line
2. Gas supply line pressure test: close valve 4 and open valve 2
3. Leak-check the gas pipe

Look for gas pipe leaks using "Typol", "1000 bulles" or a similar product. Do not use soapy water.

WARNING! Never use an open flame to check for gas leaks. Required gas pressure at the unit inlet connection are given in Gas burner data Table.

Note: To operate with propane gas, the burner is fitted with a pressure limiter (supplied by Trane)

Figure 8 - Typical gas supply Pipework

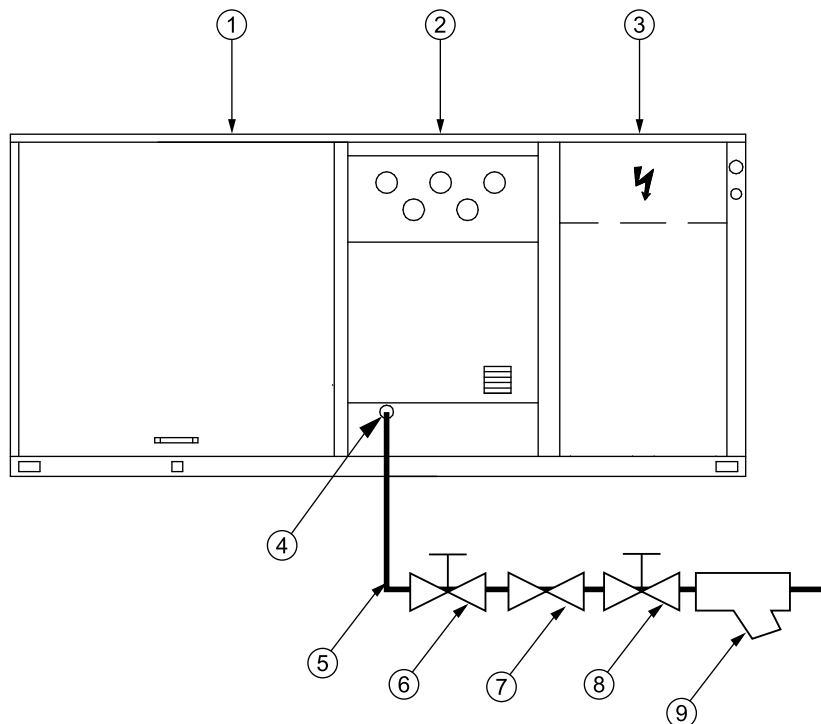

- 1 = Evaporator section
- 2 = Gas burner section
- 3 = Condenser section
- 4 = Gas supply connection

- 5 = Gas supply line
- 6.8 = Gas stop valve (Field supplied)
- 7 = Expansion valve (Field supplied)
- 9 = Filter (Field supplied)

Filter installation

To gain access to filters, remove the supply fan access panel on downflow units and the filter access panel on the end for horizontal units.

Each unit ships with 40 or 50 mm thick filters. Number and size of filters is determined by size and configuration of the unit.

CAUTION! Do not operate unit without filters in place.

The maximum pressure drops allowable on filters are:

EU2/G2: 120 Pa

EU4/G4: 150 Pa

Table 5 - Filter arrangement

UNIT	EU2		EU4	
	Qty	Size	Qty	Size
TKH / TKD / YKH / YKD 155 - 175	2x	(508x508x50)	2x	(498x498x40)
WKH / WKD / DKD / DKH 125 - 155	4x	(508x635x50)	4x	(500x625x50)
TKH / YKH 200-250 TKH / WKH / DKH 200-265-290-340	8x	(508x635x50)	8x	(500x625x50)
TKD / YKD 200-250	4x	(508x508x50)	4x	(498x498x40)
TKD / WKD / DKD 200-265-290-340	4x	(508x635x50)	4x	(500x625x50)

Supply fan adjustment

Use the following procedure to determine the proper adjustment of the supply fan for a specific application.

1. Determine total external static pressure about system and accessories.
 - a. Obtain the design airflow rate and the design external static pressure drop through the distribution system.
 - b. Add static pressure drop of the accessories installed on the unit. (Table 8)
 - c. Add the total accessory static pressure drop (from step 1b) to the design external static pressure (from step 1a). The sum of these two values is the total system external static pressure.
2. Using Table 6b or Table 9 to find the external static pressure that most closely approximates total system external static pressure. Then locate the appropriate airflow rate for your unit. The value obtained represents the brake horsepower for the supply fan motor and the fan RPM.
3. On belt driven fan, adjust motor sheave according to Table 6a.
On direct driven fan, the fan speed is adjustable through parameter [205] on the speed inverter. Direct drive fan performances are on table 6b.



Installation

Table 6a - Motor sheave / Fan speed

UNIT	Fan Speed (RPM)						
	Standard Drive						
	6 turns Open	5 turns Open	4 turns Open	3 turns Open	2 turns Open	1 turns Open	Closed
TK* / YK* 155	566	601	637	672	708	743	N/A
TK* / YK* 175	724	769	815	860	906	951	N/A
TK* / YK* 200	513	550	586	623	659	696	N/A
TK* / YK* 250	588	619	650	681	712	743	N/A
TK* 265	680	711	742	773	804	835	N/A
TK* 290	N/A	780	808	838	868	898	928
TK* 340	N/A	780	808	838	868	898	928
WK* / DK* 125	533	566	600	633	667	700	N/A
WK* / DK* 155	566	601	637	672	708	743	N/A
WK* / DK* 200	513	550	586	623	659	696	N/A
WK* / DK* 265	680	711	742	773	804	835	N/A
WK* / DK* 290	N/A	780	808	838	868	898	928
WK* / DK* 340	N/A	780	808	838	868	898	928

UNIT	Fan Speed (RPM)						
	Oversized Drive						
	6 turns Open	5 turns Open	4 turns Open	3 turns Open	2 turns Open	1 turns Open	Closed
TK* / YK* 155	672	714	756	798	840	882	N/A
TK* / YK* 175	791	840	890	939	989	1038	N/A
TK* / YK* 200	680	711	742	773	804	835	N/A
TK* / YK* 250	690	722	754	786	818	850	N/A
TK* 265	N/A	780	808	838	868	898	928
TK* 290	N/A	860	898	938	978	1018	1058
TK* 340	N/A	860	898	938	978	1018	1058
WK* / DK* 125	624	663	702	741	780	819	N/A
WK* / DK* 155	672	714	756	798	840	882	N/A
WK* / DK* 200	680	711	742	773	804	835	N/A
WK* / DK* 265	N/A	780	808	838	868	898	928
WK* / DK* 290	N/A	860	898	938	978	1018	1058
WK* / DK* 340	N/A	860	898	938	978	1018	1058

Installation

Table 9 - Belt drive supply fan performances

WK 125 External static pressure

External Static Pressure (Pa)																			
		100		150		200		250		300		350		400		450		500	
Evaporator Airflow	Fan RPM	BPH (kW)	Fan RPM	BPH (kW)	Fan RPM	BPH (kW)	Fan RPM	BPH (kW)	Fan RPM	BPH (kW)	Fan RPM	BPH (kW)	Fan RPM	BPH (kW)	Fan RPM	BPH (kW)	Fan RPM	BPH (kW)	
m ³ /h																			
5720	-	-	596	0.7	664	0.8	729	0.9	790	1.0	-	-	-	-	-	-	-	-	
6430	552	0.7	616	0.8	679	1.0	739	1.1	797	1.2	-	-	-	-	-	-	-	-	
7140	579	0.9	638	1.0	696	1.2	753	1.3	807	1.5	-	-	-	-	-	-	-	-	
7850	607	1.1	661	1.2	716	1.4	768	1.6	819	1.7	-	-	-	-	-	-	-	-	
8560	638	1.3	688	1.5	738	1.7	787	1.8	-	-	-	-	-	-	-	-	-	-	

	Standard Drive
	Oversized Drive

Note: Data includes pressure drops for standard filters and wet coil.

TK/WK 155 External static pressure

External Static Pressure (Pa)																			
		100		150		200		250		300		350		400		450		500	
Evaporator Airflow	Fan RPM	BPH (kW)	Fan RPM	BPH (kW)	Fan RPM	BPH (kW)	Fan RPM	BPH (kW)	Fan RPM	BPH (kW)	Fan RPM	BPH (kW)	Fan RPM	BPH (kW)	Fan RPM	BPH (kW)	Fan RPM	BPH (kW)	
m ³ /h																			
6800	567	0.8	628	0.9	689	1.1	747	1.2	802	1.4	856	1.5	-	-	-	-	-	-	
7650	599	1.0	654	1.2	710	1.3	763	1.5	815	1.6	865	1.8	-	-	-	-	-	-	
8500	635	1.3	686	1.5	736	1.6	785	1.8	833	2.0	880	2.1	-	-	-	-	-	-	
9350	675	1.6	721	1.8	767	2.0	812	2.2	856	2.4	-	-	-	-	-	-	-	-	
10200	719	2.0	760	2.2	802	2.4	842	2.6	-	-	-	-	-	-	-	-	-	-	

	Standard Drive
	Oversized Drive

Note: Data includes pressure drops for standard filters and wet coil.

TK 175 External static pressure

External Static Pressure (Pa)																			
		100		150		200		250		300		350		400		450		500	
Evaporator Airflow	Fan RPM	BPH (kW)	Fan RPM	BPH (kW)	Fan RPM	BPH (kW)	Fan RPM	BPH (kW)	Fan RPM	BPH (kW)	Fan RPM	BPH (kW)	Fan RPM	BPH (kW)	Fan RPM	BPH (kW)	Fan RPM	BPH (kW)	
m ³ /h																			
7870	-	-	-	-	-	-	768	1.6	819	1.7	868	1.9	916	2.1	962	2.2	1007	2.4	
8860	-	-	-	-	748	1.8	795	2.0	842	2.1	887	2.3	932	2.5	975	2.7	1018	2.9	
9850	-	-	743	2.0	786	2.2	829	2.4	871	2.6	913	2.8	954	3.0	995	3.2	1035	3.4	
10840	755	2.3	793	2.5	831	2.8	869	3.0	906	3.2	944	3.4	982	3.6	1019	3.8	-	-	
11830	815	2.9	848	3.1	881	3.3	914	3.6	948	3.8	981	4.1	1015	4.3	-	-	-	-	

	Standard Drive
	Oversized Drive

Note: Data includes pressure drops for standard filters and wet coil.



Installation

TK/WK 200 External static pressure

External Static Pressure (Pa)																				
		100		150		200		250		300		350		400		450		500		
Evaporator	Fan	BPH	Fan	BPH	Fan	BPH	Fan	BPH	Fan	BPH	Fan	BPH	Fan	BPH	Fan	BPH	Fan	BPH	Fan	BPH
Airflow	RPM	(kW)	RPM	(kW)	RPM	(kW)	RPM	(kW)	RPM	(kW)	RPM	(kW)	RPM	(kW)	RPM	(kW)	RPM	(kW)	RPM	(kW)
m ³ /h																				
8970	-	-	538	1.3	592	1.5	643	1.7	692	1.9	738	2.1	781	2.3	823	2.6	-	-	-	-
10090	-	-	561	1.6	610	1.8	657	2.0	703	2.3	747	2.5	789	2.8	829	3.0	-	-	-	-
11210	541	1.7	586	2.0	631	2.2	675	2.5	718	2.7	759	3.0	800	3.3	-	-	-	-	-	-
12330	573	2.1	615	2.4	656	2.7	696	2.9	735	3.2	774	3.5	813	3.8	-	-	-	-	-	-
13450	610	2.5	647	2.9	684	3.2	721	3.5	757	3.8	793	4.1	829	4.4	-	-	-	-	-	-

	Standard Drive
	Oversized Drive

Note: Data includes pressure drops for standard filters and wet coil.

TK 250 External static pressure

External Static Pressure (Pa)																				
		100		150		200		250		300		350		400		450		500		
Evaporator	Fan	BPH	Fan	BPH	Fan	BPH	Fan	BPH	Fan	BPH	Fan	BPH	Fan	BPH	Fan	BPH	Fan	BPH	Fan	BPH
Airflow	RPM	(kW)	RPM	(kW)	RPM	(kW)	RPM	(kW)	RPM	(kW)	RPM	(kW)	RPM	(kW)	RPM	(kW)	RPM	(kW)	RPM	(kW)
m ³ /h																				
11520	-	-	597	2.0	641	2.3	685	2.5	727	2.8	768	3.1	808	3.3	847	3.6	-	-	-	-
12960	603	2.4	642	2.7	680	3.0	718	3.3	756	3.6	793	3.9	830	4.2	-	-	-	-	-	-
14100	642	2.9	677	3.3	712	3.6	746	3.9	781	4.2	815	4.6	850	4.9	-	-	-	-	-	-
15510	695	3.6	725	4.0	755	4.4	785	4.8	815	5.1	846	5.5	-	-	-	-	-	-	-	-
16920	753	4.4	778	4.8	803	5.3	828	5.7	-	-	-	-	-	-	-	-	-	-	-	-

	Standard Drive
	Oversized Drive

Note: Data includes pressure drops for standard filters and wet coil.

TK/WK 265 External static pressure

External Static Pressure (Pa)																				
		100		150		200		250		300		350		400		450		500		
Evaporator	Fan	BPH	Fan	BPH	Fan	BPH	Fan	BPH	Fan	BPH	Fan	BPH	Fan	BPH	Fan	BPH	Fan	BPH	Fan	BPH
Airflow	RPM	(kW)	RPM	(kW)	RPM	(kW)	RPM	(kW)	RPM	(kW)	RPM	(kW)	RPM	(kW)	RPM	(kW)	RPM	(kW)	RPM	(kW)
m ³ /h																				
11520	-	-	-	-	-	-	689	2.7	731	2.9	771	3.2	811	3.5	849	3.7	887	4.0	-	-
12960	-	-	-	-	680	3.0	718	3.3	756	3.6	793	3.9	830	4.2	867	4.5	-	-	-	-
14400	-	-	686	3.4	720	3.7	754	4.1	788	4.4	821	4.8	855	5.1	889	5.4	-	-	-	-
15840	708	3.8	736	4.2	765	4.6	794	5.0	824	5.3	853	5.7	883	6.1	-	-	-	-	-	-
17280	769	4.6	792	5.1	816	5.5	840	5.9	865	6.4	889	6.8	-	-	-	-	-	-	-	-

	Standard Drive
	Oversized Drive

Note: Data includes pressure drops for standard filters and wet coil.

Installation

TK/WK 290 External static pressure

External Static Pressure (Pa)																						
	100		150		200		250		300		350		400		450		500		550		600	
Evaporator Airflow	Fan RPM	BPH (kW)	Fan RPM	BPH (kW)	Fan RPM	BPH (kW)	Fan RPM	BPH (kW)	Fan RPM	BPH (kW)	Fan RPM	BPH (kW)	Fan RPM	BPH (kW)	Fan RPM	BPH (kW)	Fan RPM	BPH (kW)	Fan RPM	BPH (kW)	Fan RPM	BPH (kW)
m ³ /h																						
12960	-	-	-	-	-	-	-	-	-	-	814	3.7	856	4.1	897	4.5	938	4.9	977	5.3	1016	5.7
14580	-	-	-	-	-	-	-	-	801	4.2	840	4.5	878	4.9	916	5.3	953	5.7	990	6.1	-	-
16200	-	-	-	-	-	-	800	4.8	836	5.2	871	5.5	906	5.9	941	6.3	975	6.7	1010	7.2	-	-
17820	-	-	-	-	811	5.6	843	6.0	876	6.4	908	6.8	940	7.2	972	7.6	1003	8.0	-	-	-	-
19440	801	6.3	831	6.6	861	7.0	891	7.4	920	7.8	950	8.2	979	8.6	1008	9.0	-	-	-	-	-	-

	Standard Drive
	Oversized Drive

Note: Data includes pressure drops for standard filters and wet coil.

TK/WK 340 External static pressure

External Static Pressure (Pa)																						
	100		150		200		250		300		350		400		450		500		550		600	
Evaporator Airflow	Fan RPM	BPH (kW)	Fan RPM	BPH (kW)	Fan RPM	BPH (kW)	Fan RPM	BPH (kW)	Fan RPM	BPH (kW)	Fan RPM	BPH (kW)	Fan RPM	BPH (kW)	Fan RPM	BPH (kW)	Fan RPM	BPH (kW)	Fan RPM	BPH (kW)	Fan RPM	BPH (kW)
m ³ /h																						
14400	-	-	-	-	-	-	-	-	795	4.1	834	4.4	873	4.8	911	5.2	949	5.6	986	6.0	-	-
16200	-	-	-	-	-	-	801	4.8	836	5.2	872	5.5	906	5.9	941	6.3	975	6.7	1009	7.2	-	-
18000	-	-	784	5.4	816	5.8	848	6.1	880	6.5	912	6.9	944	7.3	976	7.7	1007	8.1	-	-	-	-
19800	811	6.6	840	7.0	869	7.3	898	7.7	928	8.1	957	8.5	986	8.9	1016	9.4	-	-	-	-	-	-
21600	872	8.4	898	8.7	924	9.1	951	9.5	978	9.9	1005	10.4	-	-	-	-	-	-	-	-	-	-

	Standard Drive
	Oversized Drive

Note: Data includes pressure drops for standard filters and wet coil.

DK 125 External static pressure

External Static Pressure (Pa)																		
	100		150		200		250		300		350		400		450		500	
Evaporator Airflow	Fan RPM	BPH (kW)	Fan RPM	BPH (kW)	Fan RPM	BPH (kW)	Fan RPM	BPH (kW)	Fan RPM	BPH (kW)	Fan RPM	BPH (kW)	Fan RPM	BPH (kW)	Fan RPM	BPH (kW)	Fan RPM	BPH (kW)
m ³ /h																		
5720	-	-	599	0.7	667	0.8	731	0.9	792	1.1	-	-	-	-	-	-	-	-
6430	559	0.7	622	0.8	685	1.0	745	1.1	802	1.3	-	-	-	-	-	-	-	-
7140	590	0.9	649	1,0	707	1.2	762	1.3	816	1.5	-	-	-	-	-	-	-	-
7850	625	1.1	679	1,3	732	1.4	784	1.6	-	-	-	-	-	-	-	-	-	-
8560	664	1.4	714	1,6	763	1.7	811	1.9	-	-	-	-	-	-	-	-	-	-

	Standard Drive
	Oversized Drive

Note: Data includes pressure drops for standard filters and wet coil.



Installation

YK/DK 155 External static pressure

External Static Pressure (Pa)		100		150		200		250		300		350		400		450		500	
Evaporator Airflow		Fan RPM	BPH (kW)	Fan RPM	BPH (kW)	Fan RPM	BPH (kW)	Fan RPM	BPH (kW)	Fan RPM	BPH (kW)	Fan RPM	BPH (kW)	Fan RPM	BPH (kW)	Fan RPM	BPH (kW)	Fan RPM	BPH (kW)
m ³ /h																			
6800		576	0.8	637	0.9	697	1.1	755	1.2	810	1.4	863	1.5	-	-	-	-	-	-
7650		615	1.1	670	1.2	725	1.4	778	1.5	829	1.7	879	1.8	-	-	-	-	-	-
8500		661	1.4	711	1.6	761	1.7	809	1.9	857	2.1	-	-	-	-	-	-	-	-
9350		717	1.8	762	2.0	807	2.2	851	2.3	-	-	-	-	-	-	-	-	-	-
10200		782	2.3	823	2.5	864	2.7	-	-	-	-	-	-	-	-	-	-	-	-

	Standard Drive
	Oversized Drive

Note: Data includes pressure drops for standard filters and wet coil.

YK 175 External static pressure

External Static Pressure (Pa)		100		150		200		250		300		350		400		450		500	
Evaporator Airflow		Fan RPM	BPH (kW)	Fan RPM	BPH (kW)	Fan RPM	BPH (kW)	Fan RPM	BPH (kW)	Fan RPM	BPH (kW)	Fan RPM	BPH (kW)	Fan RPM	BPH (kW)	Fan RPM	BPH (kW)	Fan RPM	BPH (kW)
m ³ /h																			
7870		-	-	-	-	733	1.5	785	1.6	835	1.8	884	1.9	931	2.1	977	2.3	1021	2.5
8860		-	-	731	1.7	779	1.9	826	2.1	872	2.3	916	2.4	960	2.6	1003	2.8	-	-
9850		753	2.1	796	2.3	838	2.5	880	2.7	922	2.9	963	3.1	1003	3.3	-	-	-	-
10840		838	2.8	875	3.0	913	3.2	951	3.4	988	3.7	1026	3.9	-	-	-	-	-	-
11830		937	3.7	970	4.0	1004	4.2	1038	4.4	-	-	-	-	-	-	-	-	-	-

	Standard Drive
	Oversized Drive

Note: Data includes pressure drops for standard filters and wet coil.

YK/DK 200 External static pressure

External Static Pressure (Pa)		100		150		200		250		300		350		400		450		500		550		600	
Evaporator Airflow		Fan RPM	BPH (kW)	Fan RPM	BPH (kW)	Fan RPM	BPH (kW)	Fan RPM	BPH (kW)	Fan RPM	BPH (kW)	Fan RPM	BPH (kW)	Fan RPM	BPH (kW)	Fan RPM	BPH (kW)	Fan RPM	BPH (kW)	Fan RPM	BPH (kW)	Fan RPM	BPH (kW)
m ³ /h																							
8970		-	-	539	1.3	593	1.5	644	1.7	693	2.0	739	2.2	782	2.4	824	2.7	-	-	-	-	-	-
10090		514	1.4	564	1.7	613	1.9	660	2.1	706	2.4	749	2.6	791	2.9	832	3.2	-	-	-	-	-	-
11210		546	1.8	591	2.1	636	2.3	680	2.6	722	2.9	763	3.1	804	3.4	-	-	-	-	-	-	-	-
12330		580	2.2	621	2.5	662	2.8	702	3.1	742	3.4	781	3.7	819	4.0	-	-	-	-	-	-	-	-
13450		620	2.7	657	3.1	694	3.4	730	3.7	767	4.0	803	4.4	-	-	-	-	-	-	-	-	-	-

	Standard Drive
	Oversized Drive

Note: Data includes pressure drops for standard filters and wet coil.

Installation

YK 250 External static pressure

External Static Pressure (Pa)																			
	100		150		200		250		300		350		400		450		500		
Evaporator Airflow	Fan RPM	BPH (kW)	Fan RPM	BPH (kW)	Fan RPM	BPH (kW)	Fan RPM	BPH (kW)	Fan RPM	BPH (kW)	Fan RPM	BPH (kW)	Fan RPM	BPH (kW)	Fan RPM	BPH (kW)	Fan RPM	BPH (kW)	
m ³ /h																			
11280	-	-	601	2.1	646	2.4	689	2.7	731	3.0	772	3.2	812	3.5	-	-	-	-	-
12960	611	2.6	650	2.9	689	3.2	727	3.5	764	3.8	802	4.2	838	4.5	-	-	-	-	-
14100	654	3.2	689	3.5	723	3.9	758	4.2	793	4.5	827	4.9	-	-	-	-	-	-	-
15510	712	4.0	742	4.4	772	4.8	803	5.2	833	5.6	-	-	-	-	-	-	-	-	-
16920	776	5.0	801	5.5	827	5.9	-	-	-	-	-	-	-	-	-	-	-	-	-

	Standard Drive
	Oversized Drive

Note: Data includes pressure drops for standard filters and wet coil.

DK 265 External static pressure

External Static Pressure (Pa)																			
	100		150		200		250		300		350		400		450		500		
Evaporator Airflow	Fan RPM	BPH (kW)	Fan RPM	BPH (kW)	Fan RPM	BPH (kW)	Fan RPM	BPH (kW)	Fan RPM	BPH (kW)	Fan RPM	BPH (kW)	Fan RPM	BPH (kW)	Fan RPM	BPH (kW)	Fan RPM	BPH (kW)	
m ³ /h																			
11520	-	-	-	-	-	-	693	2.8	735	3.1	775	3.4	815	3.6	853	3.9	891	4.2	-
12960	-	-	-	-	689	3.2	727	3.5	764	3.8	802	4.2	838	4.5	875	4.8	-	-	-
14400	-	-	699	3.7	733	4.0	767	4.4	800	4.7	834	5.1	868	5.4	-	-	-	-	-
15840	727	4.2	755	4.6	784	5.0	814	5.4	843	5.8	873	6.2	-	-	-	-	-	-	-
17280	793	5.3	817	5.8	842	6.2	866	6.7	891	7.1	-	-	-	-	-	-	-	-	-

	Standard Drive
	Oversized Drive

Note: Data includes pressure drops for standard filters and wet coil.



Installation

DK 290 External static pressure

External Static Pressure (Pa)																							
		100		150		200		250		300		350		400		450		500		550		600	
Evaporator	Fan	BPH	Fan	BPH	Fan	BPH	Fan	BPH	Fan	BPH	Fan	BPH	Fan	BPH	Fan	BPH	Fan	BPH	Fan	BPH	Fan	BPH	
Airflow	RPM	(kW)	RPM	(kW)	RPM	(kW)	RPM	(kW)	RPM	(kW)	RPM	(kW)	RPM	(kW)	RPM	(kW)	RPM	(kW)	RPM	(kW)	RPM	(kW)	
m ³ /h																							
12960	-	-	-	-	-	-	-	-	-	780	3.5	823	3.8	865	4.2	906	4.6	946	4.9	985	5.3	-	-
14580	-	-	-	-	-	-	-	-	-	817	4.3	855	4.7	893	5.0	931	5.4	968	5.8	1004	6.3	-	-
16200	-	-	-	-	791	4.7	827	5.1	862	5.5	897	5.8	932	6.2	967	6.6	1001	7.1	-	-	-	-	-
17820	787	5.4	820	5.8	852	6.1	885	6.5	917	6.9	949	7.3	981	7.7	1013	8.1	-	-	-	-	-	-	-
19440	864	7.0	893	7.4	922	7.8	952	8.2	981	8.6	1010	9.1	-	-	-	-	-	-	-	-	-	-	-

	Standard Drive
	Oversized Drive

Note: Data includes pressure drops for standard filters and wet coil.

DK 340 External static pressure

External Static Pressure (Pa)																							
		100		150		200		250		300		350		400		450		500		550		600	
Evaporator	Fan	BPH	Fan	BPH	Fan	BPH	Fan	BPH	Fan	BPH	Fan	BPH	Fan	BPH	Fan	BPH	Fan	BPH	Fan	BPH	Fan	BPH	
Airflow	RPM	(kW)	RPM	(kW)	RPM	(kW)	RPM	(kW)	RPM	(kW)	RPM	(kW)	RPM	(kW)	RPM	(kW)	RPM	(kW)	RPM	(kW)	RPM	(kW)	
m ³ /h																							
14400	-	-	-	-	-	-	-	-	-	810	4.2	849	4.6	888	5.0	926	5.3	964	5.7	1001	6.1	-	-
16200	-	-	-	-	790	4.7	826	5.0	861	5.4	896	5.8	931	6.2	965	6.6	1000	7.0	-	-	-	-	-
18000	795	5.5	827	5.9	859	6.3	891	6.6	923	7.0	955	7.4	986	7.9	1018	8.3	-	-	-	-	-	-	-
19800	879	7.5	908	7.9	937	8.3	967	8.7	996	9.1	-	-	-	-	-	-	-	-	-	-	-	-	-
21600	970	9.8	998	10.3	-	-	-	-	-	-	-	-	-	-	-	-	-	-	-	-	-	-	-

	Standard Drive
	Oversized Drive

Note: Data includes pressure drops for standard filters and wet coil.

Installation

Table 6b - Direct drive Evaporator fan performances

WK*125

External Static Pressure (Pa)																																		
		100			150			200			250			300			350			400			450			500			550			600		
Evaporator Airflow	Fan RPM	VFD Hz	BPH (kW)	Fan RPM	VFD Hz	BPH (kW)	Fan RPM	VFD Hz	BPH (kW)	Fan RPM	VFD Hz	BPH (kW)	Fan RPM	VFD Hz	BPH (kW)	Fan RPM	VFD Hz	BPH (kW)	Fan RPM	VFD Hz	BPH (kW)	Fan RPM	VFD Hz	BPH (kW)	Fan RPM	VFD Hz	BPH (kW)	Fan RPM	VFD Hz	BPH (kW)				
m ³ /h																																		
5720	528	27.6	0.5	596	31.2	0.6	664	34.7	0.7	729	38.1	0.8	790	41.3	0.9	847	44.3	1.1	902	47.1	1.2	953	49.8	1.4	1000	34.5	1.5	1044	36.0	1.7	1085	37.4	1.8	
6430	552	28.9	0.6	616	32.2	0.7	679	35.5	0.9	739	38.6	1.0	797	41.6	1.1	851	44.5	1.2	903	47.2	1.4	953	49.8	1.5	1000	34.5	1.7	1044	36.0	1.9	1085	37.4	2.0	
7140	579	30.3	0.8	638	33.3	0.9	696	36.4	1.0	753	39.3	1.2	807	42.1	1.3	859	44.9	1.5	909	47.5	1.6	956	50.0	1.8	1002	34.6	1.9	1046	36.1	2.1	1087	37.5	2.2	
7850	607	31.7	1.0	661	34.6	1.1	716	37.4	1.3	768	40.1	1.4	819	42.8	1.5	868	45.4	1.7	916	47.9	1.8	962	33.2	2.0	1007	34.7	2.2	1050	36.2	2.3	1091	37.6	2.5	
8560	638	33.3	1.2	688	35.9	1.4	738	38.5	1.5	787	41.1	1.6	834	43.6	1.8	881	46.0	2.0	926	48.4	2.1	971	33.5	2.3	1014	35.0	2.5	1056	36.4	2.6	1097	37.8	2.8	

TK*/WK*155

External Static Pressure (Pa)																																		
		100			150			200			250			300			350			400			450			500			550			600		
Evaporator Airflow	Fan RPM	VFD Hz	BPH (kW)	Fan RPM	VFD Hz	BPH (kW)	Fan RPM	VFD Hz	BPH (kW)	Fan RPM	VFD Hz	BPH (kW)	Fan RPM	VFD Hz	BPH (kW)	Fan RPM	VFD Hz	BPH (kW)	Fan RPM	VFD Hz	BPH (kW)	Fan RPM	VFD Hz	BPH (kW)	Fan RPM	VFD Hz	BPH (kW)	Fan RPM	VFD Hz	BPH (kW)	Fan RPM	VFD Hz	BPH (kW)	
m ³ /h																																		
6800	567	29.6	0.7	628	32.8	0.8	689	36.0	1.0	747	39.0	1.1	802	41.9	1.2	856	44.7	1.4	907	47.4	1.5	955	49.9	1.6	1001	34.5	1.8	1045	36.0	2.0	1087	37.5	2.1	
7650	599	31.3	0.9	654	34.2	1.1	710	37.1	1.2	763	39.9	1.3	815	42.6	1.5	865	45.2	1.6	913	47.7	1.8	960	33.1	1.9	1005	34.7	2.1	1048	36.1	2.3	1090	37.6	2.4	
8500	635	33.2	1.2	686	35.8	1.3	736	38.5	1.5	785	41.0	1.6	833	43.5	1.8	880	46.0	1.9	926	48.4	2.1	970	33.5	2.3	1014	35.0	2.4	1056	36.4	2.6	1097	37.8	2.8	
9350	675	35.3	1.5	721	37.7	1.6	767	26.4	1.8	812	28.0	2.0	856	29.5	2.1	899	31.0	2.3	942	32.5	2.5	985	33.9	2.6	1026	35.4	2.8	1067	36.8	3.0	1107	38.2	3.2	
10200	719	24.8	1.8	760	26.2	2.0	802	27.6	2.2	842	29.1	2.3	883	30.4	2.5	923	31.8	2.7	963	33.2	2.9	1003	34.6	3.1	1042	35.9	3.3	1081	37.3	3.5	1120	38.6	3.7	

TK*175

External Static Pressure (Pa)																																		
		100			150			200			250			300			350			400			450			500			550			600		
Evaporator Airflow	Fan RPM	VFD Hz	BPH (kW)	Fan RPM	VFD Hz	BPH (kW)	Fan RPM	VFD Hz	BPH (kW)	Fan RPM	VFD Hz	BPH (kW)	Fan RPM	VFD Hz	BPH (kW)	Fan RPM	VFD Hz	BPH (kW)	Fan RPM	VFD Hz	BPH (kW)	Fan RPM	VFD Hz	BPH (kW)	Fan RPM	VFD Hz	BPH (kW)	Fan RPM	VFD Hz	BPH (kW)	Fan RPM	VFD Hz	BPH (kW)	
m ³ /h																																		
7870	608	31.8	1.0	662	34.6	1.1	716	37.4	1.3	768	40.1	1.4	819	42.8	1.6	868	45.4	1.7	916	47.9	1.9	962	33.2	2.0	1007	34.7	2.2	1050	36.2	2.4	1091	37.6	2.5	
8860	651	34.0	1.3	699	36.5	1.5	748	39.1	1.6	795	41.5	1.8	842	44.0	1.9	887	30.6	2.1	932	32.1	2.3	975	33.6	2.4	1018	35.1	2.6	1060	36.5	2.8	1100	37.9	3.0	
9850	700	24.1	1.7	743	25.6	1.8	786	27.1	2.0	829	28.6	2.2	871	30.0	2.4	913	31.5	2.5	954	32.9	2.7	995	34.3	2.9	1035	35.7	3.1	1075	37.1	3.3	1114	38.4	3.5	
10840	755	26.0	2.1	793	27.3	2.3	831	28.7	2.5	869	30.0	2.7	906	31.3	2.9	944	32.6	3.1	982	33.8	3.3	1019	35.1	3.5	1056	36.4	3.7	1094	37.7	3.9	1131	39.0	4.1	
11830	815	28.1	2.6	848	29.2	2.8	881	30.4	3.0	914	31.5	3.2	948	32.7	3.4	981	33.8	3.7	-	-	-	-	-	-	-	-	-	-	-	-	-	-		

TK*/WK*200

External Static Pressure (Pa)																																		
		100			150			200			250			300			350			400			450			500			550			600		
Evaporator Airflow	Fan RPM	VFD Hz	BPH (kW)	Fan RPM	VFD Hz	BPH (kW)	Fan RPM	VFD Hz	BPH (kW)	Fan RPM	VFD Hz	BPH (kW)	Fan RPM	VFD Hz	BPH (kW)	Fan RPM	VFD Hz	BPH (kW)	Fan RPM	VFD Hz	BPH (kW)	Fan RPM	VFD Hz	BPH (kW)	Fan RPM	VFD Hz	BPH (kW)	Fan RPM	VFD Hz	BPH (kW)	Fan RPM	VFD Hz	BPH (kW)	
m ³ /h																																		
8970	484	24.9	0.9	538	27.9	1.1	592	30.7	1.2	643	33.4	1.4	692	35.9	1.6	738	38.3	1.8	781	40.6	2.0	823	42.7	2.1	862	44.7	2.3	898	46.6	2.5	932	48.4	2.7	
10090	513	26.5	1.1	561	29.1	1.3	610	31.7	1.5	657	34.1	1.7	703	36.5	1.9	747	38.8	2.1	789	41.0	2.3	829	43.1	2.5	868	45.1	2.7	905	47.0	2.9	940	48.8	3.2	
11210	540	28.0	1.4	586	30.4	1.6	631	32.8	1.8	675	35.1	2.1	718	37.3	2.3	759	39.4	2.5	800	41.5	2.7	839	43.5	2.9	877	45.5	3.2	913	47.4	3.4	949	49.3	3.6	
12330	575	29.7	1.7	615	31.9	2.0	656	34.0	2.2	696	36.1	2.5	735	38.2	2.7	774	40.2	2.9	813	42.2	3.2	850	44.1	3.4	887	46.0	3.7	923	47.9	3.9	959	49.7	4.2	
13450	609	31.6	2.1	647	33.6	2.4	684	35.5	2.6	721	37.4	2.9	757	39.3	3.2	793	41.2	3.4	829	43.0	3.7	865	44.9	4.0	900	46.7	4.2	935	48.5	4.5	-	-	-	

- Standard Drive
- Oversized Drive

Note: Data given for unit with standard filters and without options
 BHP = Motor shaft power
 VFD Hz = TR1-2800 inverter speed reference frequency setpoint



Installation

TK*250

External Static Pressure (Pa)																																		
		100			150			200			250			300			350			400			450			500			550			600		
Evaporator Airflow	Fan RPM	VFD Hz	BPH (kW)	Fan RPM	VFD Hz	BPH (kW)	Fan RPM	VFD Hz	BPH (kW)	Fan RPM	VFD Hz	BPH (kW)	Fan RPM	VFD Hz	BPH (kW)	Fan RPM	VFD Hz	BPH (kW)	Fan RPM	VFD Hz	BPH (kW)	Fan RPM	VFD Hz	BPH (kW)	Fan RPM	VFD Hz	BPH (kW)	Fan RPM	VFD Hz	BPH (kW)				
m ³ /h																																		
11280	552	18.9	1.5	597	20.5	1.7	641	22.0	1.9	685	23.5	2.1	727	24.9	2.3	768	26.3	2.6	808	27.7	2.8	847	29.0	3.0	885	30.3	3.3	921	31.6	3.5	956	32.8	3.7	
12960	603	20.7	2.0	642	22.0	2.3	680	23.3	2.5	718	24.6	2.8	756	25.9	3.0	793	27.2	3.3	830	28.5	3.5	867	29.7	3.8	903	30.9	4.0	938	32.2	4.3	973	33.4	4.5	
14100	642	22.0	2.4	677	23.2	2.7	712	24.4	3.0	746	25.6	3.3	781	26.8	3.5	815	27.9	3.8	850	29.1	4.1	884	30.3	4.4	918	47.6	4.6	952	49.4	4.9	-	-	-	
15510	695	23.8	3.0	725	24.8	3.3	755	25.9	3.7	785	40.7	4.0	815	42.3	4.3	846	43.9	4.6	877	45.5	4.9	908	47.1	5.2	-	-	-	-	-	-	-	-		
16920	753	39.0	3.7	778	40.3	4.0	803	41.6	4.4	828	43.0	4.7	-	-	-	-	-	-	-	-	-	-	-	-	-	-	-	-	-	-	-	-		

TK*/WK*265

External Static Pressure (Pa)																																		
		100			150			200			250			300			350			400			450			500			550			600		
Evaporator Airflow	Fan RPM	VFD Hz	BPH (kW)	Fan RPM	VFD Hz	BPH (kW)	Fan RPM	VFD Hz	BPH (kW)	Fan RPM	VFD Hz	BPH (kW)	Fan RPM	VFD Hz	BPH (kW)	Fan RPM	VFD Hz	BPH (kW)	Fan RPM	VFD Hz	BPH (kW)	Fan RPM	VFD Hz	BPH (kW)	Fan RPM	VFD Hz	BPH (kW)	Fan RPM	VFD Hz	BPH (kW)	Fan RPM	VFD Hz	BPH (kW)	
m ³ /h																																		
11520	559	19.2	1.6	603	20.7	1.8	646	22.2	2.0	689	23.6	2.2	731	25.0	2.4	771	26.4	2.7	811	27.8	2.9	849	29.1	3.1	887	30.4	3.4	923	31.6	3.6	959	32.9	3.8	
12960	603	20.7	2.0	642	22.0	2.3	680	23.3	2.5	718	24.6	2.8	756	25.9	3.0	793	27.2	3.3	830	28.5	3.5	867	29.7	3.8	903	30.9	4.0	938	32.2	4.3	973	33.4	4.5	
14400	653	22.4	2.6	686	23.5	2.8	720	24.7	3.1	754	25.8	3.4	788	27.0	3.7	821	28.1	4.0	855	29.3	4.3	889	46.1	4.5	922	47.8	4.8	956	49.6	5.1	-	-	-	
15840	708	24.3	3.2	736	25.2	3.5	765	26.2	3.8	794	41.2	4.1	824	42.7	4.5	853	44.3	4.8	-	-	-	-	-	-	-	-	-	-	-	-	-	-	-	
17280	769	39.9	3.9	792	41.1	4.2	816	42.3	4.6	-	-	-	-	-	-	-	-	-	-	-	-	-	-	-	-	-	-	-	-	-	-	-		

TK*/WK*290

External Static Pressure (Pa)																																		
		100			150			200			250			300			350			400			450			500			550			600		
Evaporator Airflow	Fan RPM	VFD Hz	BPH (kW)	Fan RPM	VFD Hz	BPH (kW)	Fan RPM	VFD Hz	BPH (kW)	Fan RPM	VFD Hz	BPH (kW)	Fan RPM	VFD Hz	BPH (kW)	Fan RPM	VFD Hz	BPH (kW)	Fan RPM	VFD Hz	BPH (kW)	Fan RPM	VFD Hz	BPH (kW)	Fan RPM	VFD Hz	BPH (kW)	Fan RPM	VFD Hz	BPH (kW)	Fan RPM	VFD Hz	BPH (kW)	
m ³ /h																																		
12960	595	30.8	2.0	639	33.0	2.2	684	35.3	2.5	728	37.6	2.8	771	39.8	3.1	814	42.0	3.4	856	44.2	3.7	897	46.3	4.0	938	48.4	4.4	977	33.5	4.7	1016	34.9	5.1	
14580	643	33.0	2.6	683	35.2	2.9	723	37.3	3.2	762	39.3	3.5	801	41.3	3.8	840	43.3	4.1	878	45.3	4.4	916	47.3	4.8	953	49.2	5.1	990	34.0	5.5	1027	35.2	5.9	
16200	693	35.8	3.4	729	37.6	3.7	765	39.5	4.0	800	41.3	4.3	836	43.1	4.7	871	44.9	5.0	906	46.7	5.3	941	48.5	5.7	975	33.5	6.1	1010	34.6	6.5	1044	35.8	6.9	
17820	747	38.6	4.5	779	40.2	4.8	811	41.8	5.1	843	43.5	5.4	876	45.2	5.7	908	46.8	6.1	940	48.5	6.4	972	33.3	6.8	1003	34.4	7.2	1035	35.5	7.6	1067	36.6	8.0	
19440	801	41.3	5.6	831	42.9	6.0	861	44.4	6.3	891	46.0	6.6	920	47.5	7.0	950	32.6	7.4	979	33.6	7.7	1008	34.6	8.1	1038	35.6	8.5	1067	36.6	8.9	1096	37.6	9.4	

TK*/WK*340

External Static Pressure (Pa)																																		
		100			150			200			250			300			350			400			450			500			550			600		
Evaporator Airflow	Fan RPM	VFD Hz	BPH (kW)	Fan RPM	VFD Hz	BPH (kW)	Fan RPM	VFD Hz	BPH (kW)	Fan RPM	VFD Hz	BPH (kW)	Fan RPM	VFD Hz	BPH (kW)	Fan RPM	VFD Hz	BPH (kW)	Fan RPM	VFD Hz	BPH (kW)	Fan RPM	VFD Hz	BPH (kW)	Fan RPM	VFD Hz	BPH (kW)	Fan RPM	VFD Hz	BPH (kW)	Fan RPM	VFD Hz	BPH (kW)	
m ³ /h																																		
14400	636	32.9	2.6	676	34.9	2.8	716	36.9	3.1	756	39.0	3.4	795	41.0	3.7	834	43.1	4.0	873	45.1	4.3	911	47.0	4.7	949	49.0	5.0	986	33.9	5.4	1023	35.1	5.8	
16200	693	35.8	3.5	729	37.6	3.7	765	39.5	4.0	801	41.3	4.3	836	43.2	4.7	872	45.0	5.0	906	46.8	5.3	941	48.5	5.7	975	33.5	6.1	1009	34.6	6.4	1042	35.8	6.8	
18000	752	38.6	4.6	784	40.4	4.9	816	42.1	5.2	848	43.8	5.5	880	45.4	5.9	912	47.1	6.2	944	48.7	6.6	976	33.5	6.9	1007	34.6	7.3	1038	35.6	7.7	1069	36.7	8.1	
19800	810	42.0	5.9	840	43.4	6.3	869	44.9	6.6	898	30.8	6.9	928	31.8	7.3	957	32.8	7.7	986	33.8	8.0	1016	34.9	8.4	1045	35.9	8.8	1075	36.9	9.3	1104	37.9	9.7	
21600	872	29.8	7.5	898	30.8	7.9	924	31.7	8.2	951	32.6	8.6	978	33.6	9.0	1005	34.5	9.3	1033	35.4	9.7	-	-	-	-	-	-	-	-	-	-	-		

- Standard Drive
- Oversized Drive

Note: Data given for unit with standard filters and without options
 BPH = Motor shaft power
 VFD Hz = TR1-2800 inverter speed reference frequency setpoint

Installation

To increase airflow

Loosen variable sheave set screw and turn sheave clockwise.

To decrease airflow

Loosen variable sheave set screw and turn sheave counter-clockwise.

To increase belt tension

Loosen the nut (next to the idler sheave) that secures the sheave in place. With a wrench, apply pressure clockwise on the outside nut (round headed one), until tension desired is reached. While holding pressure with the tension nut, retighten the nut next to the idler sheave.

Refer to Table 7 to find appropriate belt tension settings.

Table 7 - Belt tensioning

	Unit	Size	Motor kW	Fan pulley Type /diam. (mm)	Motor pulley Type /diam. (mm)	Belt type/ length (mm)	Belt deflexion (mm)	Deflexion effort mini kg	Deflexion effort maxi kg	Belt tension mini N	Belt tension maxi N
STD	WKD / DKD	125	2.2	BK90 / 222	1VP44 / 105	BX62 / 1575	5.9	2.4	2.9	400	500
STD	TKD / YKD / WKD / DKD	155	2.2	BK85 / 210	1VP44 / 105	BX62 / 1575	6.0	2.4	2.9	400	500
STD	TKD / YKD	175	3	BK130 / 324	1VP44 / 105	BX68 / 1727	6.1	2.4	2.9	400	500
STD	TKD / YKD / WKD / DKD	200	3	BK160 / 400	1VL40 / 95	BX75 / 1905	7.0	2.4	2.9	400	500
STD	TKD / YKD	250	4.6	BK190 / 467	1VP50 / 121	BX81 / 2057	6.9	2.4	2.9	400	500
STD	TKD / WKD / DKD	265	4.6	BK190 / 467	1VP56 / 136	BX81 / 2057	6.3	2.4	2.9	400	500
STD	TKD / WKD / DKD	290	7.5	BK190H / 467	PVA1-156A / 138	BX85 / 2204	7.0	2.4	2.9	400	500
STD	TKD / WKD / DKD	340	7.5	BK190H / 467	PVA1-156A / 138	BX85 / 2204	7.0	2.4	2.9	400	500
OVR	TKD / WKD / DKD	125	3	BK130 / 324	1VP44 / 105	BX68 / 1727	5.9	2.4	2.9	400	500
OVR	TKD / YKD / WKD / DKD	155	3	BK140 / 349	1VP44 / 105	BX70 / 1778	6.2	2.4	2.9	400	500
OVR	TKD / YKD	175	4.6	BK120 / 300	1VP44 / 105	BX68 / 1727	5.5	2.4	2.9	400	500
OVR	TKD / YKD / WKD / DKD	200	4.6	BK190 / 467	1VP56 / 136	BX81 / 2057	6.9	2.4	2.9	400	500
OVR	TKD / YKD	250	4.6	BK190 / 467	1VP56 / 136	BX81 / 2057	6.3	2.4	2.9	400	500
OVR	TKD / WKD / DKD	265	5.5	BK190 / 467	PVA1-156A / 138	BX81 / 2057	6.3	2.4	2.9	400	500
OVR	TKD / WKD / DKD	290	9	BK190H / 467	PVA1-178B / 155	BX85 / 2204	7.0	2.4	2.9	400	500
OVR	TKD / WKD / DKD	340	9	BK190H / 467	PVA1-178B / 155	BX85 / 2204	7.0	2.4	2.9	400	500
STD	TKH / WKH / DKH	125	2.2	BK90 / 222	1VP44 / 105	BX68 / 1727	5.9	2.4	2.9	400	500
STD	TKH / YKH / WKH / DKH	155	2.2	BK85 / 210	1VP44 / 105	BX68 / 1727	6.0	2.4	2.9	400	500
STD	TKH / YKH	175	3	BK130 / 324	1VP44 / 105	BX75 / 1905	6.1	2.4	2.9	400	500
STD	TKH / YKH / WKH / DKH	200	3	BK160 / 400	1VL40 / 95	BX90 / 2286	7.0	2.4	2.9	400	500
STD	TKH / YKH	250	4.6	BK190 / 467	1VP50 / 121	BX96 / 2438	6.9	2.4	2.9	400	500
STD	TKH / WKH / DKH	265	4.6	BK190 / 467	1VP56 / 136	BX96 / 2438	6.3	2.4	2.9	400	500
STD	TKH / WKH / DKH	290	7.5	BK190H / 467	PVA1-156A / 138	BX90 / 2286	6.3	2.4	2.9	400	500
STD	TKH / WKH / DKH	340	7.5	BK190H / 467	PVA1-156A / 138	BX90 / 2286	6.3	2.4	2.9	400	500
OVR	TKH / WKH / DKH	125	3	BK130 / 324	1VP44 / 105	BX75 / 1905	5.9	2.4	2.9	400	500
OVR	TKH / YKH / WKH / DKH	155	3	BK140 / 349	1VP44 / 105	BX77 / 1955	6.2	2.4	2.9	400	500
OVR	TKH / YKH	175	4.6	BK120 / 300	1VP44 / 105	BX75 / 1905	5.5	2.4	2.9	400	500
OVR	TKH / YKH / WKH / DKH	200	4.6	BK190 / 467	1VP56 / 136	BX96 / 2438	6.9	2.4	2.9	400	500
OVR	TKH / YKH	250	4.6	BK190 / 467	1VP56 / 136	BX96 / 2438	6.3	2.4	2.9	400	500
OVR	TKH / WKH / DKH	265	5.5	BK190 / 467	PVA1-156A / 138	BX96 / 2438	6.3	2.4	2.9	400	500
OVR	TKH / WKH / DKH	290	9	BK190H / 467	PVA1-178B / 155	BX96 / 2438	6.3	2.4	2.9	400	500
OVR	TKH / WKH / DKH	340	9	BK190H / 467	PVA1-178B / 155	BX96 / 2438	6.3	2.4	2.9	400	500

Installation

Figure 9 - Typical fan, motor, and sheave assembly

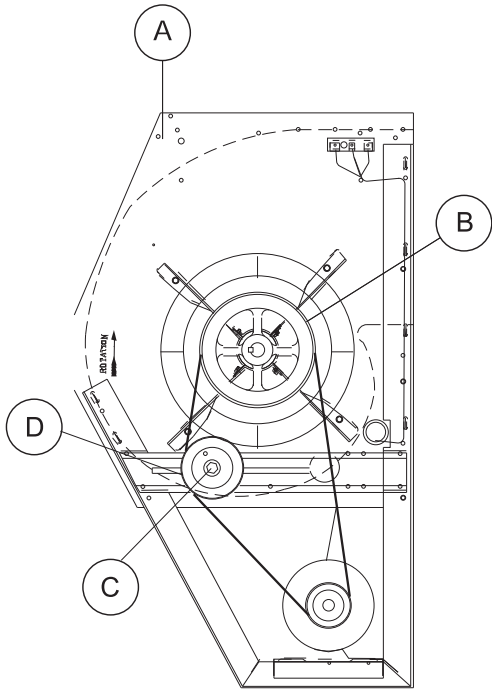

- A = Fan Housing
- B = Fan Sheave
- C = Belt Tension Adjustment Bolt
- D = Idler Pulley

Figure 10 - Typical direct drive fan, motor, and sheave assembly

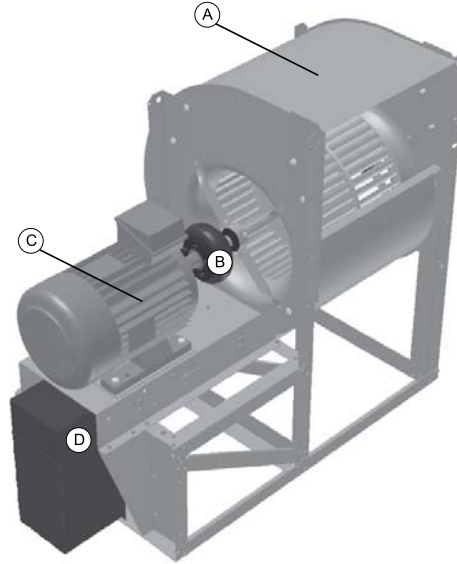

- A = Fan Housing
- B = Direct coupling
- C = Motor
- D = Speed inverter

Component air pressure drops

Table 8 - Static pressure drop through accessories

	Airflow	Filter EU2	Filter EU4	Economizer 100% outside air	Economizer 100% return air	Electric heater (TK*/WK* only)	Hot water coil * (TKD/WKD only)	Gas Burner (YK*/DK* only)
	5720	9	21	6	5	4	37	2
WKD/WKH	6430	11	24	7	6	6	45	5
DKD/DKH	7140	14	27	9	6	7	53	9
125	7850	17	30	10	7	9	62	16
	8560	20	33	12	8	12	72	26
TKD/TKH	6800	13	27	8	6	7	33	7
YKD/YKH	7650	16	30	10	7	9	40	14
WKD/WKH	8500	19	34	12	8	11	48	25
DKD/DKH	9350	22	37	14	9	13	56	45
155	10200	26	40	16	10	16	65	76
	7870	17	30	10	7	10	42	16
TKD/TKH	8860	21	34	12	8	13	51	33
YKD/YKH	9850	25	38	15	9	16	61	61
175	10840	30	43	17	11	19	72	109
	11830	35	47	20	12	23	83	184
TKD	8970	12	26	29	6	13	33	1
YKD	10090	15	30	37	8	17	40	3
WKD	11210	19	33	45	9	21	48	5
DKD	12330	23	37	55	11	25	56	8
200	13450	27	41	65	13	30	65	13
	8970	11	23	33	6	13	-	1
TKH	10090	14	26	41	8	17	-	3
YKH	11210	17	29	51	9	21	-	5
WKH	12330	20	33	61	11	25	-	8
DKH	13450	23	36	72	13	30	-	13
200	11280	18	32	46	10	20	49	5
	12690	24	36	58	12	25	59	11
TKD	14100	29	41	71	14	32	71	17
YKD	15510	36	46	86	17	38	82	29
250	16920	43	51	102	19	46	95	47
	11280	17	30	52	10	19	-	5
TKH	12690	21	34	65	12	24	-	11
YKH	14100	26	38	80	14	29	-	17
250	15510	31	43	96	17	35	-	29
	16920	36	47	114	19	42	-	47
	11520	20	34	48	10	22	49	5
TKD	12960	25	39	60	12	28	59	11
WKD	14400	31	44	75	15	35	71	19
DKD	15840	38	49	90	18	42	83	33
265	17280	45	54	107	21	50	95	53
	11520	18	30	53	10	22	-	5
TKH	12960	22	35	67	12	28	-	11
WKH	14400	26	39	82	15	35	-	19
DKH	15840	31	43	99	18	42	-	33
265	17280	37	48	117	21	50	-	53
	12960	25	39	60	12	28	59	11
TKD	14580	32	45	76	15	35	72	21
WKD	16200	40	50	94	18	44	86	37
DKD	17820	48	56	114	22	53	100	63
290	19440	57	61	135	26	64	116	104
	12960	22	35	67	12	28	-	19
TKH	14580	27	39	84	15	35	-	37
WKH	16200	33	44	103	18	44	-	67
DKH	17820	39	49	124	22	53	-	115
290	19440	46	54	147	26	64	-	187
	14400	31	44	75	15	35	71	19
TKD	16200	40	50	94	18	44	86	37
WKD	18000	49	56	116	22	55	102	67
DKD	19800	60	63	141	26	66	119	115
340	21600	71	69	167	31	79	138	187
	14400	26	39	82	15	35	-	19
TKH	16200	33	44	103	18	44	-	37
WKH	18000	40	50	127	22	55	-	67
DKH	19800	47	56	153	26	66	-	115
340	21600	55	61	181	31	79	-	187

*Add only if greater than return air pressure drop

Installation

WARNING! If a speed inverter is installed, it has to be configured according to mains source. Please refer to page 40 for more information on inverter supply.

Electrical connection

The electric panel is located in the unit compressor section. Remove the compressor access panel. The unit is designed to run with 400 V +/- 5%/50 Hz/ 3 ph.

Factory supplied Disconnect switch (Option on sizes 125 to 250. Standard on sizes 265-290-340)

The disconnect switch is factory mounted. It is located on the side of the Electrical panel and equipped with fuses as standard.

Over current protection

The branch circuit feeding the unit must be protected in accordance with national or local codes and max unit amps indicated in Electrical Data tables on following pages.

Power wiring

The unit power supply must be provided by 4-wire cable with cross-sectional areas complying with legislation.

The power supply cables must be laid in leak-tight pipes and pass through the bottom of the electric panel. The cables must not be taut.

Appropriate connectors must be provided. Flexible pipe supports are required to prevent noise transmission in the building structure. Ensure all the connections are tightened.

Note:

1. earthing must be executed in accordance with local legislation.
2. the machines are designed for a short-circuit current of 10 kA. In the event of a higher application, contact your Trane sales office.

Figure 11 - Power supply

TKD/TKH. WKD/WKH units:

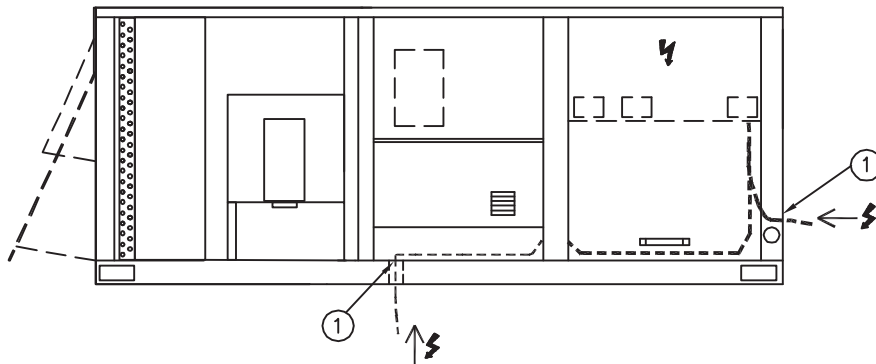

YKD/YKH. DKD/DKH units:

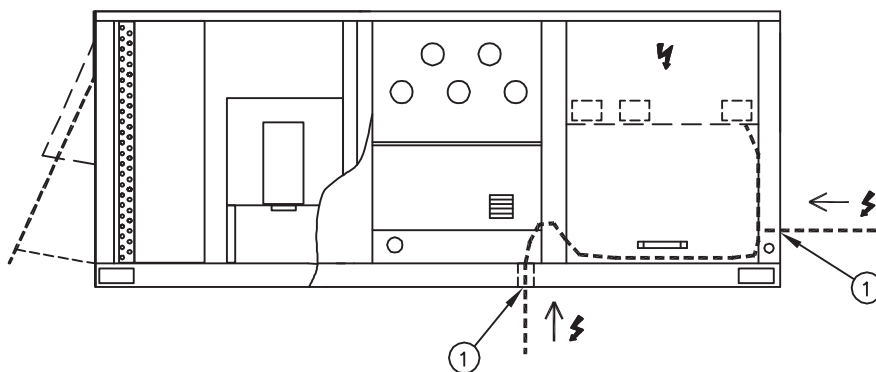

1 = Power supply from the bottom or from the side.

Installation

Scroll compressors

Compressor electrical phasing

Proper phasing of the electrical power wiring is critical for proper operation and reliability of the scroll compressor and fans.

Proper rotation of the scroll compressor must be established before the unit is started. This is accomplished by confirming that the electrical phase sequence of the power supply is correct. The motor is internally connected for clockwise rotation with the inlet power supply phased A, B, C.

The unit is protected against reverse rotation by a phase protection relay that monitors phase loss and phase reversal.

The direction of rotation may be reversed by interchanging any two of the line wires.

CAUTION! After completion of wiring, check all electrical connections, and ensure all connections are tight. Replace and secure all electrical box covers and access doors before leaving unit or connecting power to circuit supplying unit.

CAUTION! Units with Scroll compressors are not equipped with crankcase heaters.

WARNING!

Disconnect all power, including remote disconnects, and discharge all capacitors before servicing. Follow proper lockout/tagout procedures to ensure the power cannot be inadvertently energized. After power is removed, allow 4 minutes for capacitors to discharge. Verify with an appropriate voltmeter that all capacitors have discharged. Failure to disconnect power and/or discharge capacitors before servicing could result in death or serious injury. For additional information regarding the safe discharge of capacitors, see Trane Service Bulletin PROD-SVB06A.

Unit	Control Max Amps	Compressor 1 / 2		Indoor Fan Belt Drive		Indoor Fan Direct Drive		Exhaust fan Max Amps	Outdoor Fan Qty	Outdoor Fan Max Amps	Electric Heat Max Amps
		Max Amps	Start Amps	Standard drive Max Amps	Oversized drive Max Amps	Standard drive Max Amps	Oversized drive Max Amps				
TK* / YK* 155	0.5	18.5 / 11.2	142 / 82	4	6.4	5.4	8.5	3.0	2	1.2	36
TK* / YK* 175	0.5	20.0 / 13.9	142 / 87	6.4	9	5.4	9.8	3.0	2	1.2	36
TK* / YK* 200	0.5	18.5 / 18.5	142 / 142	6.4	9	9.4	12.4	3.0	2	2.5	54
TK* / YK* 250	0.5	20.0 / 20.0	142 / 142	9	9	11.3	13.3	3.0	2	2.5	54
TK* 265	0.5	23.0 / 23.0	147 / 147	9	11	11.3	13.5	3.0	2	2.5	54
TK* 290	0.5	25.2 / 25.2	158 / 158	15	17.3	16.4	23.3	3.0	3	2.5	54
TK* 340	0.5	29.0 / 29.0	197 / 197	15	17.3	16.6	22.9	3.0	3	2.5	54
WK* / DK* 125	0.5	13.9 / 13.9	87 / 87	4	6.4	5.5	7.9	3.0	2	1.2	36
WK* / DK* 155	0.5	15.2 / 15.2	98 / 98	4	6.4	5.4	8.5	3.0	2	1.2	36
WK* / DK* 200	0.5	20.0 / 20.0	142 / 142	6.4	9	9.4	12.4	3.0	2	2.5	54
WK* / DK* 265	0.5	23.0 / 23.0	147 / 147	9	11	11.3	13.5	3.0	2	2.5	54
WK* / DK* 290	0.5	25.2 / 25.2	158 / 158	15	17.3	16.4	23.3	3.0	4	1.2	54
WK* / DK* 340	0.5	29.0 / 29.0	197 / 197	15	17.3	16.6	22.9	3.0	4	1.2	54

Data for nominal voltage 400V/3/50

Data are subject to change without notice. Please refer to unit nameplate data.

Controls

Control wiring

The control circuit is 24 V AC. Unit includes a 400/24 V transformer.

WARNING! The unit disconnect switch must be opened and locked open. Risk of injury and electrocution.

CAUTION! The unit 24 V transformer must not be used to power accessories mounted on site. other than those proposed by Trane.

Unit controlled by thermostat

Figure 12 - Thermostat wiring

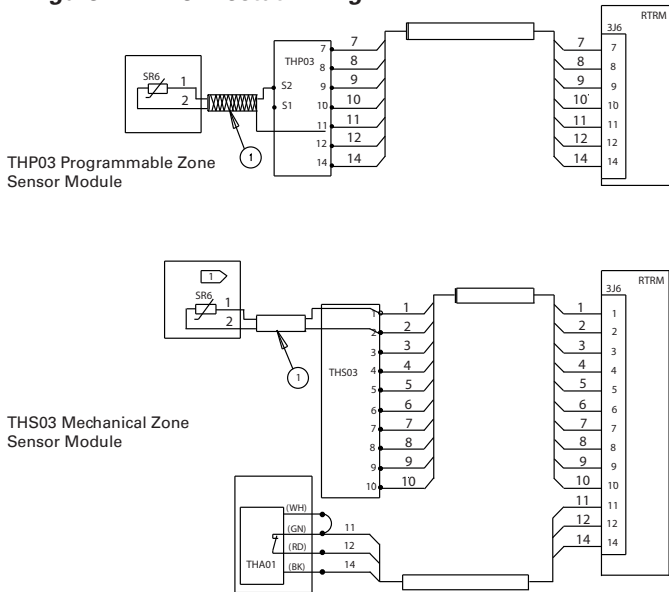

Trane THS01, THS02, and THP01 Thermostats are directly connected to RTRM board (J7 connector). TRANE THS02 and THP03 thermostats are directly connected to RTRM board (J6 connector).

Install the electrical link between the thermostat (thermostat terminal strip) and the unit (J6 or J7 connector) in compliance with the interconnection diagram. The low voltage wiring must not be laid in the same pipes as the power cables.

The sizes and lengths of the thermostat connection wires are given in the following table. The total resistance of these control cables must not exceed 5 ohms. If the resistance exceeds this value the thermostat may not operate with the same precision.

Table 11 - Zone sensor wire size and maximum length

	Wire size (mm ²)	Maximum wire length (m)
THS/THP 03	0.33	45
	0.5	76
	0.75	115
	1.3	185
	2	300
Conventional thermostat	0.33	10
	0.5	15
	0.75	23
	1.3	37
	2	60

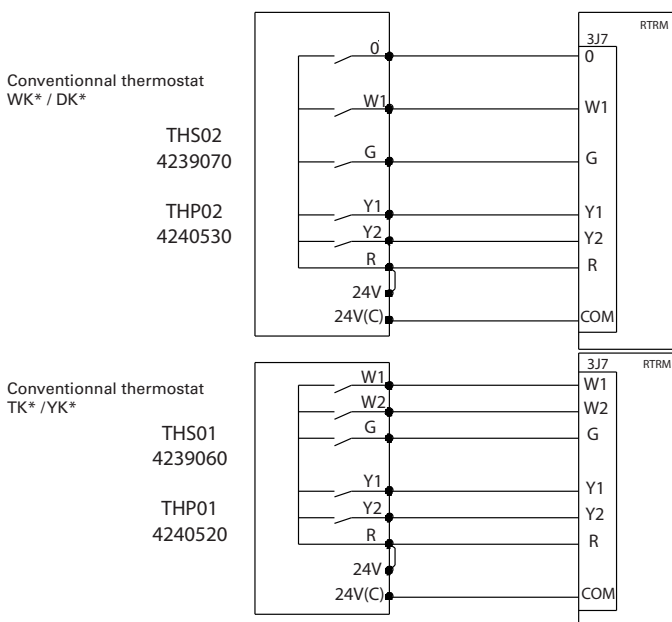

Unit controlled by BAS

Each unit must be equipped with a TCI-R board. A communication bus (twisted shielded pair) must link each TCI-R to the Trane RoofTop Manager (RTM) or to the communication gateway (in the case of an external BAS). Connect one temperature sensor to each unit. LonTalk® communication interface LTCI-R board allows ICS communication between a ReliaTel™ unit and LonTalk® communication applications.

Unit controlled by Tracker™ supervisor

The units must also be equipped with the TCI-R communication board. One remote sensor is required on each unit for a constant flow volume. In the case of a variable flow installation (VariTrac™) these sensors must not be installed. A twisted shielded pair must be used for the communication link. The main functions of the Tracker™ supervisor are control of setpoints, timetable management (Programming) and display of faults. For more details refer to the supervisor documentation.

Remote ON/OFF with optional RTOM

Voyager rooftops are micro controlled. Starting and stopping the unit (fans, compressor, change-over etc..) is normally managed by the thermostat, the Tracker™ or the control device connected to the unit. Sometimes, the client still wants to have a simple switch to start and stop the unit: a remote ON/OFF option.

This can be done via the Option board (RTOM). Place AUTO/OFF contact to RTOM, terminal J6-1 & J6-2.

Emergency Stop terminal

Emergency Stop terminal is available on normally closed contact between X20 and X21 (see figure below).

Figure 13 - RTRM card

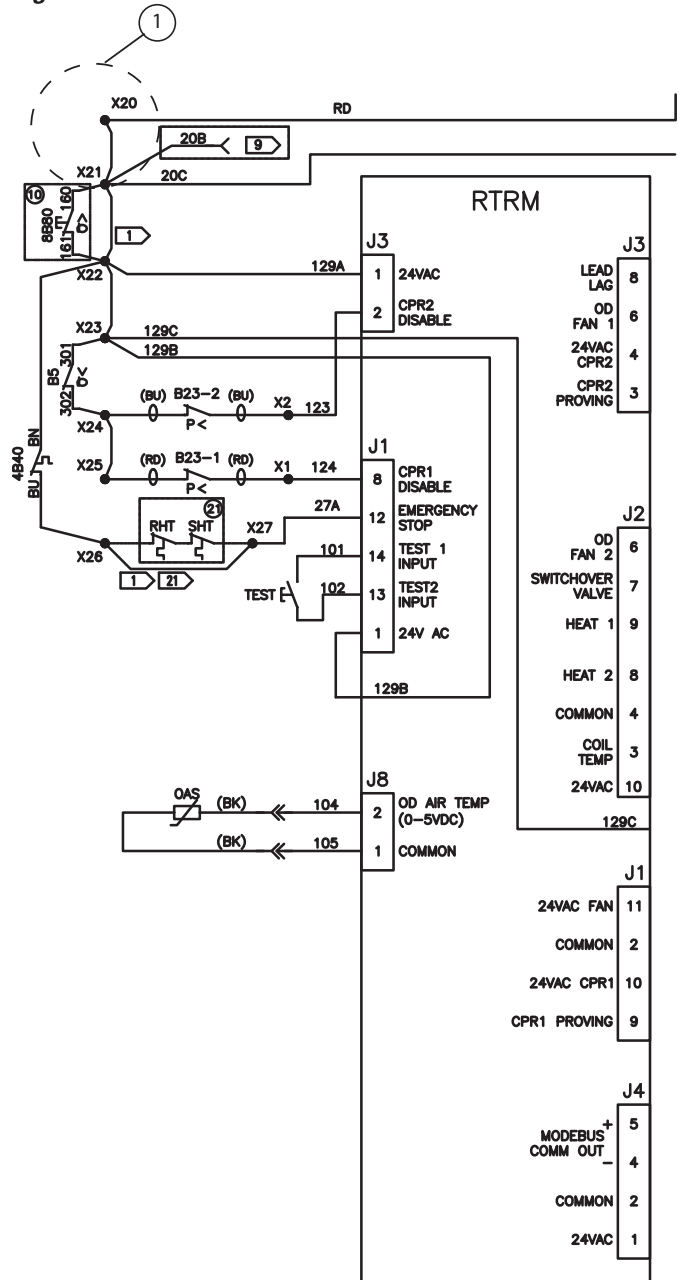

1 = X20 and X21

Controls

CO₂ sensors

Table 12 - Specifications

	Wall-mounted	Duct-mounted
Measuring range CO ₂		0-200 ppm
Accuracy at 25°C	<+/- [40 ppm CO ₂ + 3% of reading] (included repeatability and calibration uncertainty)	<+/- [30 ppm CO ₂ + 2% of reading] (included repeatability and calibration uncertainty)
Non-linearity		<1.0% full scale
Temperature dependence of output		0.3% full scale/°C
Long-term stability		<5.0% full scale / 5 years
Recommended calibration interval		5 years
Response time		1 minute (0-63%)
Operating temperature	15-35°C	- 5-45°C
Storage temperature	-20-70°C	
Humidity range		0-85% relative humidity
Airflow range		0-10 m/s)
Output signals (jumper selectable)		0-10Vdc
Resolution of analog outputs		10 ppm CO ₂
Recommended external load		Ohms min. 1000
Power supply		Nominal 24Vac
Power consumption		<5 VA
Warm-up time		<15 minutes
Dimensions (mm)	108 x 80 x 36	80 x 80 x 200

Power supply requirements

CAUTION! Make sure that you connect the power wire only to the 24V terminal. Connecting the power wire to the output terminal may result in equipment damage. The CO₂ sensor is designed to operate with a nominal 24 Vac supply. The power supply should maintain the voltage between 20 to 26 Vac.

Table 13 - CO₂ sensor wire size

Cross section (mm ²)	Maximum wire length (m)
0.25	50
0.5	100
1	200

Wiring the wall-mounted CO₂ sensor

DVC setpoint potentiometer on economizer module can be adjusted as follows:

0% - 500ppm. 50% - 1000 ppm.
100% - 1500ppm

The outside air damper will modulate from minimum position setting to up to 100% while attempting to maintain the CO₂ setpoint.

To connect the wall mounted CO₂ sensor. Refer to **the wiring diagram provided in the unit.**

Wiring the duct-mounted CO₂ sensor

1. Connect the DCV signal wire to the connector DCV of the RTEM.
2. Connect the power according to the guidelines in Power supply requirements.

To connect the wall mounted CO₂ sensor, Refer to the wiring diagram provided in the unit.

Figure 14 - Jumper settings

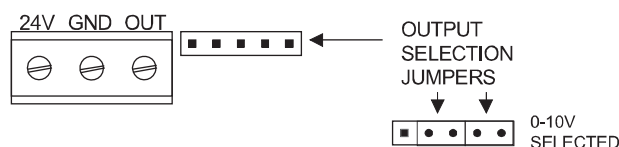

Mounting the wall-mounted sensor

1. Select a proper location in the room to mount the CO₂ sensor. Look for an interior wall with good air circulation, approximately 1.4 m from the floor.
2. Remove the back plate from the sensor and thread the power wires and output signal wire through the hole in the back plate.

For surface wiring, make cut-outs with pliers to the thinner section of the upper or lower edge of the back plate and to thread the wires through.

3. Mount the back plate to the wall with screws. Note that the arrow on the back plate shows the mounting direction.

Mounting the duct-mounted CO₂ sensor

1. Select a proper location on the duct to mount the CO₂ sensor.
2. Drill a 22-25 mm hole in the mounting surface for sensor insertion (Figure 13).
3. Attach the mounting plate to the duct wall with four screws (See following figure).
4. Insert the sensor through the mounting plate, adjusting the depth for optimal air sensing.

CO₂ sensor maintenance

This CO₂ sensor has excellent stability and requires no maintenance. In most environments the recommended calibration interval is five years. A trained service technician can use a portable CO₂ meter to certify sensor calibration. If, when checking the sensor, the reading differs too much from the reference value, the sensor can be recalibrated in the field. A calibration kit, software, and calibration gases are required. If certified accuracy is required, the sensor must be calibrated against accurate and traceable calibration gases in a laboratory. Consult Trane BAS for further details.

Figure 15 - RTEM module setting for CO₂ sensor

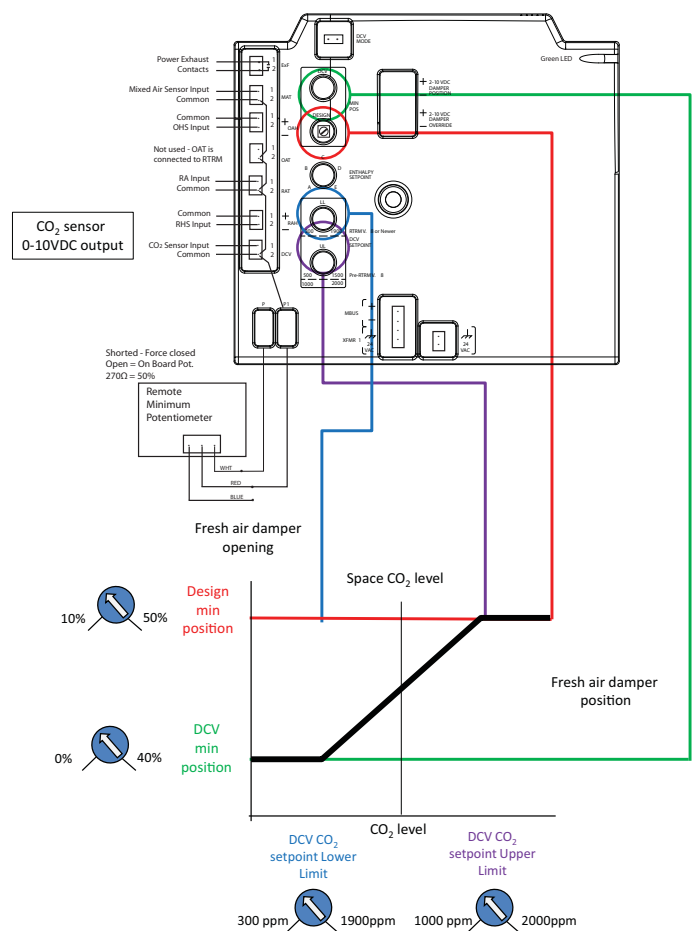

Controls

Remote potentiometer

To install the remote potentiometer, cut the jumper WL on the economizer RTEM board, and connect the wires to P and P1.

Note: This potentiometer allows to adjust the permanent fresh air intake from 0 to 50%.

0 W corresponds to closed fresh air damper.

270 W corresponds to 50% open fresh air damper.

Note: This potentiometer allows to adjust the permanent fresh air intake from 0 to 50%.

0 W corresponds to closed fresh air damper.

270 W corresponds to 50% open fresh air damper.

Figure 16 - Remote potentiometer dimensions

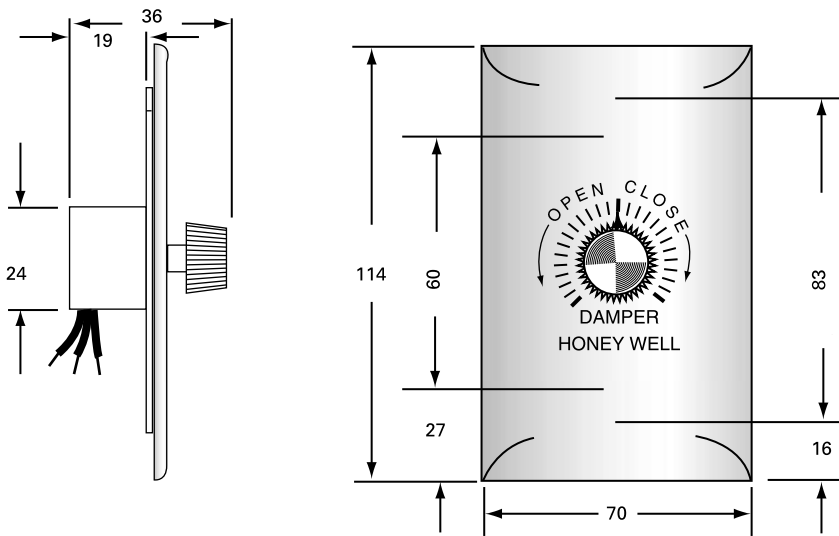
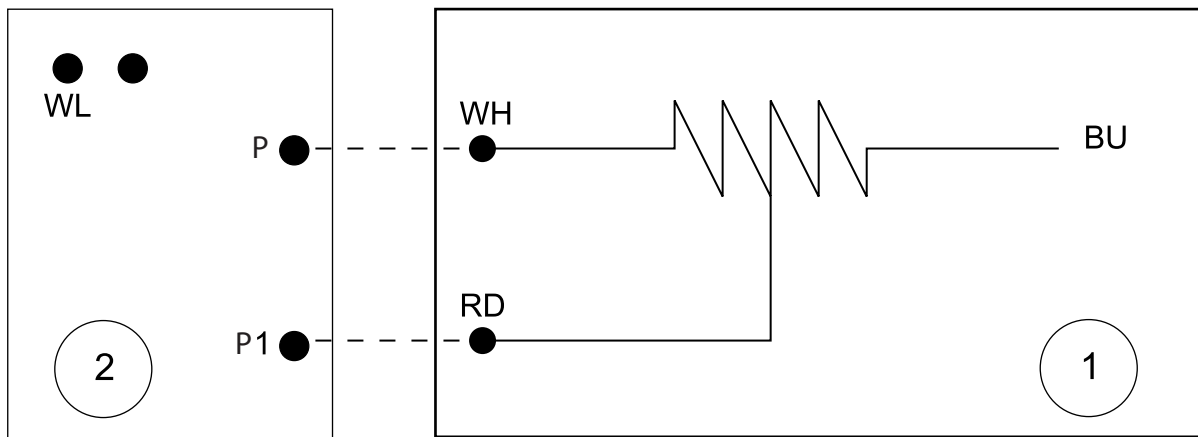

Figure 17 - Remote potentiometer wiring



1 = Remote potentiometer

2 = RTEM Board

WH = White wire

RD = Red Wire

BU = Blue wire

_____ Factory wiring

----- Field wiring

Fire thermostat

There are two sensors in the fire thermostat Kit: Sensor X13100040-01 is factory-set to open at 57°C. Sensor X13100040-02 is set to open at 115°C.

Sensors are mounted directly in the ductwork. They should be installed where elements can respond quickly to air temperature changes. If not possible, the sensor may be installed on a suitable bracket so the air is drawn across the element. Sensor X13100040-01 has to be mounted in the return air duct. Sensor X13100040-02 has to be mounted in the supply air duct.

Note: Do not permit element guard to touch internal parts. Do not locate sensor where the air circulation is restricted by baffles.

Connection of the fire thermostat with TCI board : Refer to the wiring diagram provided in the unit.

Connection without TCI board

Connect according to the standard wiring diagram provided on the unit.

Remove sensor cover and fasten control securely with screws. Loads connected must not exceed 2 amps, 30V Ac.

Figure 18 - Duct mounting of fire thermostat

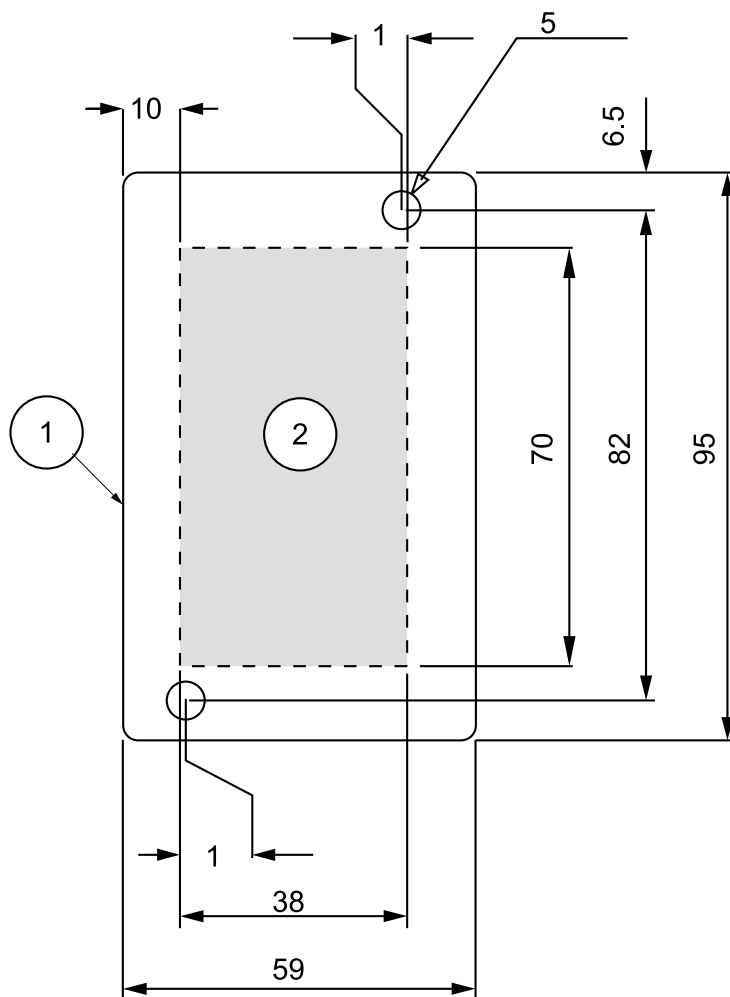

- 1 = Fire thermostat
- 2 = Hole in the duct



Controls

Clogged filter detector

This device is mounted in the filter section. The sensor measures the difference in pressure before and after the filter section. The information is sent to the THP03 thermostat, to a Tracker™ or to a BMS.

Smoke detector

This device is used to detect smoke in the air stream. It includes a factory mounted detector connected to a central panel, both fitted in the fan section.

When smoke is detected, it shuts off the unit. A dry contact is available on the control panel for a remote default.

High temperature safety thermostat

This additional safety device is a manual reset thermostat for gas fired units (YKD/YKH), required mainly by the French ERP regulation. It is located in the gas burner section. It stops the gas burner and the supply air fan when the supply air temperature rises to 120°C.

Remote fault relay

This is a factory mounted relay used to send alarm signals (dry contact) to a local BMS or a local control panel. With this relay, the compressor, heating, fan and power supply alarm output signals from the controller are reported to a single dry contact.

Thermostats

Two thermostats are available:

THS03/THP03.

“THS” are non programmable thermostats, “THP” are programmable.

Table 14 - Characteristics of Programmable and Conventional Thermostats

		THS03	THP03
Programmable	•	-	•
Electronic	•	-	•
Control type design	Electro-mechanical		Reliatel
For cooling-only units (TS*/TK*)	•	•	•
For heat pump units (WS*/WK*)	•	•	•
For gas-fired units (YS*/YK*)	•	•	•
Number of cooling stages	2	3	3
Auxiliary heating stages (electric heater, hot water coil)	2	2 / 1 Modulating	
Liquid crystal display	•	-	•

• Available

- Not Available

Other accessories available

Remote temperature sensor to be used with THS 03 / THP 03:

TZS01: Remote room temperature sensor to be used with THS/THP 03, Tracker or Varitrac systems.

DTS: Duct temperature sensor to be used with THS/THP 03

TZS02: Remote room temperature sensor with adjustable thumbwheel setpoint to be used with Tracker or Varitrac systems

Refer to separate documentation for more information.

Communication Interfaces

TRANE Communication Interface (TCI-R) board

This is an electronic board, factory-mounted in the main control panel, needed to allow communication between a TRANE Integrated Comfort system (Varitrac CCP3) and the unit. (COM3-COM4)

LON Communication Interface (LCI-R) board

This is an electronic board, factory-mounted in the main control panel, needed to allow communication on a LonTalk[®] Network at the unit level.

LonTalk[®]. Communication Interface (LCI-R) board

This interface board allows Voyager units to communicate on a LonTalk[®] Network at the unit level. Network variables are based on the LonMark[®]. Space Comfort Controller Functional Profile Template. The LCI-R uses a Free Topology transceiver FTT-10A. The FTT-10A transceiver supports non-polarity sensitive, free topology wiring, allowing the system installer to use star, bus, and loop architecture. The LCI-R can also be connected to an optional High Temperature Limit Switch if installed with the rooftop unit. For more information, see attached manual LTCl-IN-1.

LCI-R is mandatory when the rooftop is controlled by a Tracker centralized controller.

Modbus Communication (PIC)

This interface needs a TCI-R to operate. The PIC is the gateway allowing communication between a Trane equipment and a BMS (Building Management Systems) through the Modbus protocol over a RS232 or a RS-485 link.

The PIC handles Modbus RTU according to the Reference Guide: Modicon PI-MBUS-300 Rev. D

Modicon[®] is a trademark of Modicon, Inc.

Refer to manual BAS-SVX08C for detailed information.

Unit Options

Hot water coil

(Down flow units only)

In order to prevent water to freeze up in the coil during unoccupied period or shutdown limited period, a thermostat opens when there is a risk of freeze-up. The services of a water treatment specialist are recommended if water used can cause scaling deposits or erosion. Insulate all the water piping likely to be exposed to freezing temperatures in order to avoid freeze up of the coil and heat losses. The water distribution network must be fitted with vents in places where air is likely to be trapped.

The hot water coil is factory mounted in the discharge section. Two holes are provided to connect the hot water coil. They are located at the base of the unit. Remove the central panel to access the coil, using an 8 mm wrench (the bolts are located on the bottom part of the panels). The tubes for entering and leaving water are equipped with a threaded female connector.

Water connection inlet/outlet: 1 ¼" ISO R7.

Hot water coil: Installation and connection

In order to prevent water to freeze up in the coil during unoccupied period or shutdown limited period, it is recommended to use ethylene glycol. The services of a water treatment specialist are recommended if water used can cause scaling deposits or erosion. Insulate all the water piping likely to be exposed to freezing temperatures in order to avoid freeze up of the coil and heat losses. The water distribution network must be fitted with vents in places where air is likely to be trapped.

Table 15 - Ethylene glycol percentage

Ethylene glycol percentage (%)	Freezing point (°C)
10	-4
20	-10

Figure 19 - Hot water coil connections

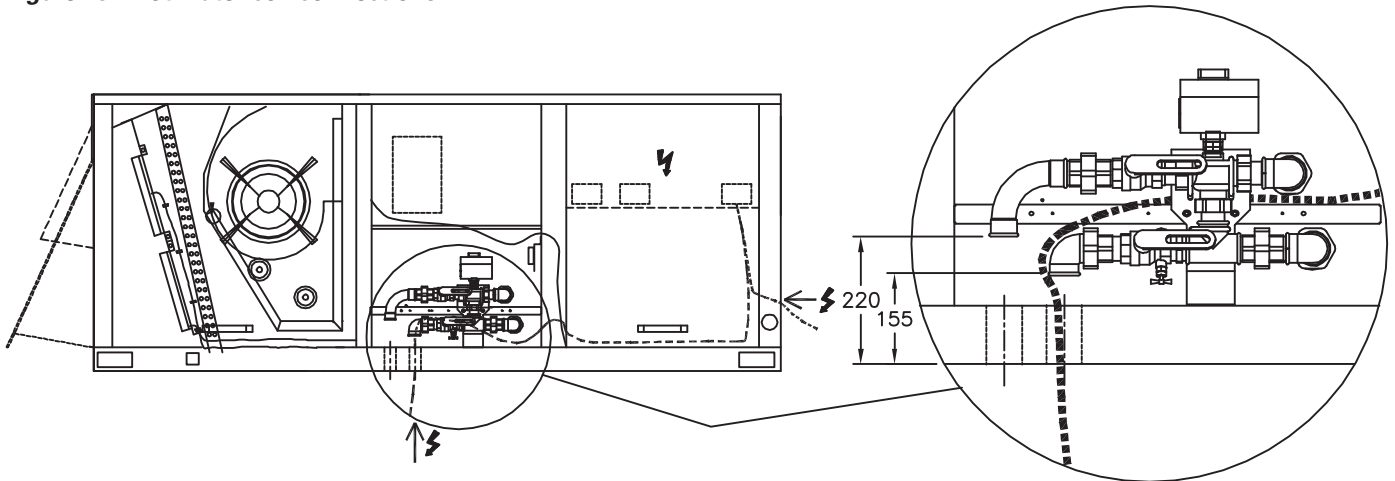

Unit Options

Electric Heater

Electric heaters are fitted on the fan discharge. Heaters have two heating stages and provided with two types of overheat thermostats:

- Automatic reset thermostats which stop the electric heater when the air temperature rises to 76°C. Automatic reset at 60°C. No alarm output available.
- The manual reset thermostat which stop the unit when the air temperature rises to 120°C. No alarm output available.

Soft Starter

The soft starter is used to achieve a progressive supply fan start and a reduced starting current as well as the motor starting torque. This option is well adapted for textile duct applications. It is factory installed in the main control panel.

The soft starter gradually increases the voltage of the supply fan motor until it reaches full line voltage.

The starting time can be adjusted from 0 to 64 seconds but the soft starter is factory set to the maximum starting time value, 64 seconds.

Figure 20 - Soft starter

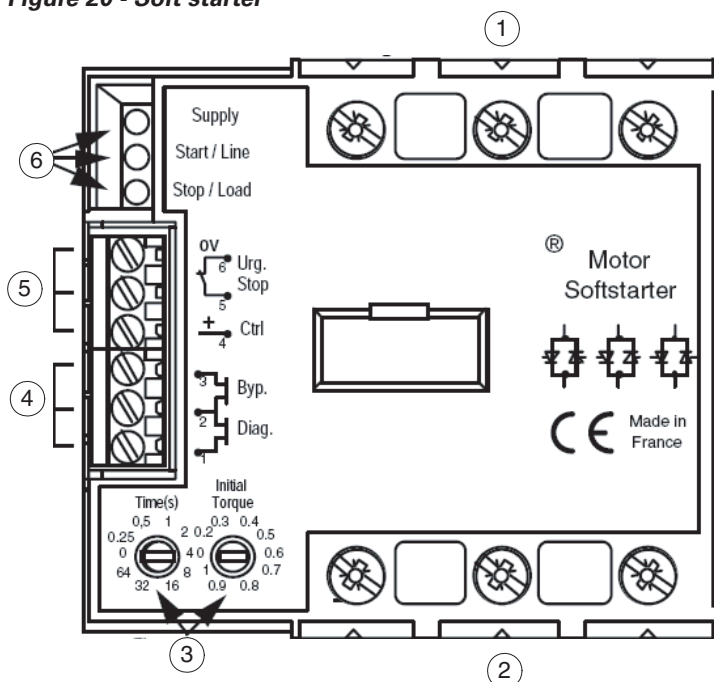

- 1 = Three phase mains connections
- 2 = Motor connections
- 3 = Settings
- 4 = Status outputs
- 5 = Controls
- 6 = LEDs

Unit Options

80 - 100% Supply fan Frequency Inverter

The 80-100% frequency inverter is a factory installed, programmed and tested option, used mainly to lower operation and maintenance costs.

It can be used also to adjust the air flow and for textile duct applications.

The inverters drive the supply fan motors at 80% or 100% of the nominal speed according to the cooling and the heating capacity steps of the rooftops. Inverters are electrically enslaved to the compressors and gas burner contactors.

The starting time is factory set at 60 seconds but can be adjusted on site with the VFD parameter n°207.

When both options "2 speed inverter" and "fan failure switch" are ordered at the same time, the starting time must not exceed 90 seconds. The nominal speed of the motor can be adjusted on site with the VFD parameter n°205. Refer to Table 37 to adjust nominal speed (parameter [205]) and ramp up time (parameter [207]).

CAUTION! Unit with speed inverter shall not operate in outdoor ambient temperature higher than 46°C.

High voltage WARNING!

The voltage of the frequency converter is dangerous whenever the converter is connected to mains. Consequently, it is essential to comply with the instructions in the Inverter manual.

These rules concern your safety:

1. The frequency converter must be disconnected from the mains if repair work is to be carried out. Check that the mains has been disconnected and that the prescribed time has passed before removing motor and mains plugs.
2. The [STOP/RESET] key on the control panel of the frequency converter does not disconnect the equipment from mains and is thus not to be used as a safety switch.

3. The earth leakage currents are higher than 3.5 mA.
4. Do not remove the plugs for the motor - and mains while the frequency converter is connected to mains. Check that the mains has been disconnected and that the prescribed time has passed before removing motor and mains plugs.
5. Note that the frequency converter has more voltage inputs than L1, L2 and L3 when the DC bus terminals are used. Check that all voltage inputs are disconnected and that the prescribed time has passed before repair work is commenced.

It can be extremely dangerous to touch the electrical parts even when the mains supply has been disconnected.

Also ensure that other voltage inputs are disconnected from load sharing through the DC bus.

Wait at least 14 minutes after the input power has been removed before servicing the drive.

WARNING! against unintended start

1. The motor can be brought to a stop by means of digital commands, bus commands, references or a local stop, while the frequency converter is connected to mains. If personal safety considerations make it necessary to ensure that no unintended start occurs, these stop functions are not sufficient.
2. While parameters are being changed, the motor may start. Consequently, the stop key [STOP/RESET] must always be activated, following which data can be modified.
3. A motor that has been stopped may start if faults occur in the electronics of the frequency converter, or if a temporary overload or a fault in the supply mains or the motor connection ceases.

In any case, the operator must be out of the unit when the unit is connected to mains.

Unit Options

Table 16 - VFD Direct drive data - Nominal speed and ramp up time

Unit	Size	Motor kW	Nb of poles	Motor RPM	VFD reference setting : parameter [205]						Factory setting
					Factory setting			Adjusted ramp-up time for effective 60 sec ramp parameter [207]			
					Nominal speed Hz / RPM	Minimum speed Hz / RPM	Maximum speed Hz / RPM				
WK* / DK*	125	2.2	6 Poles	957 RPM	40.5 Hz 775 RPM	31.0 Hz 593 RPM	50.0 Hz 957 RPM			60.0 s	
TK* / YK* / WK* / DK*	155	2.2	6 Poles	957 RPM	40.5 Hz 775 RPM	31.0 Hz 593 RPM	50.0 Hz 957 RPM			60.0 s	
TK* / YK*	175	2.2	6 Poles	957 RPM	40.5 Hz 775 RPM	31.0 Hz 593 RPM	50.0 Hz 957 RPM			60.0 s	
TK* / YK* / WK* / DK*	200	4	6 Poles	963 RPM	39.0 Hz 751 RPM	28.0 Hz 539 RPM	50.0 Hz 963 RPM			60.0 s	
TK* / YK*	250	7.5	4 Poles	1455 RPM	27.0 Hz 786 RPM	20.0 Hz 582 RPM	34.0 Hz 989 RPM			88.2 s	
TK* / WK* / DK*	265	7.5	4 Poles	1455 RPM	27.0 Hz 786 RPM	20.0 Hz 582 RPM	34.0 Hz 989 RPM			88.2 s	
TK* / WK* / DK*	290	7.5	6 Poles	970 RPM	41.5 Hz 805 RPM	33.0 Hz 640 RPM	50.0 Hz 970 RPM			60.0 s	
TK* / WK* / DK*	340	7.5	6 Poles	970 RPM	41.5 Hz 805 RPM	33.0 Hz 640 RPM	50.0 Hz 970 RPM			60.0 s	
WK* / DK*	125	5.5	4 Poles	1455 RPM	28.5 Hz 829 RPM	20.4 Hz 593 RPM	39.0 Hz 1135 RPM			76.9 s	
TK* / YK* / WK* / DK*	155	5.5	4 Poles	1455 RPM	29.7 Hz 864 RPM	20.4 Hz 593 RPM	39.0 Hz 1135 RPM			76.9 s	
TK* / YK*	175	5.5	4 Poles	1455 RPM	33.1 Hz 962 RPM	20.4 Hz 593 RPM	39.0 Hz 1135 RPM			76.9 s	
TK* / YK* / WK* / DK*	200	5.5	6 Poles	963 RPM	40.2 Hz 774 RPM	28.0 Hz 539 RPM	50.0 Hz 963 RPM			60.0 s	
TK* / YK*	250	5.5	6 Poles	963 RPM	43.2 Hz 832 RPM	30.2 Hz 582 RPM	50.0 Hz 963 RPM			60.0 s	
TK* / WK* / DK*	265	5.5	6 Poles	963 RPM	44.0 Hz 847 RPM	30.2 Hz 582 RPM	50.0 Hz 963 RPM			60.0 s	
TK* / WK* / DK*	290	15	4 Poles	1457 RPM	32.6 Hz 951 RPM	22.0 Hz 640 RPM	38.0 Hz 1107 RPM			79.0 s	
TK* / WK* / DK*	340	15	4 Poles	1457 RPM	33.4 Hz 974 RPM	22.0 Hz 640 RPM	38.0 Hz 1107 RPM			79.0 s	

To change ramp-up time, use the following formula :

$$\text{parameter [207]} = \text{desired ramp up time (s)} \times \frac{50}{\text{Maximum speed (Hz)}}$$

For example, to raise ramp up time to 75s on a YKD250 standard drive, set parameter [207] = 110

Unit Options

RFI switch Mains supply isolated from earth:

If the frequency converter is supplied from an isolated mains source (IT mains), the RFI switch can be turned off (OFF). In OFF position, the internal RFI capacities (filter capacitors) between the chassis and the intermediate circuit are cut off to avoid damage to the intermediate circuit and to reduce the earth capacity currents (according to IEC 61800-3).

NB! The RFI switch is not to be operated with mains connected to the unit. Check that the mains supply has been disconnected before operating the RFI switch.

NB! The RFI switch disconnects the capacitors galvanically from ground.

The switch Mk9, placed next to terminal 96, should be removed to disconnect the RFI-filter.

The RFI switch is only available on TR1 2880-2882 (11,00 and 15,00 kW).

With IT mains, it is recommended to protect the rooftops with a 300 mm differential switch.

• Control unit

On the front of the frequency converter there is a control panel.

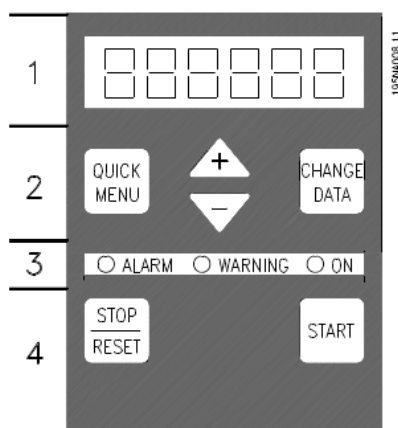

The control panel is divided into four function groups:

1. Six-digit LED display.
2. Keys for changing parameters and shifting display function.
3. Indicator lamps.
4. Keys for local operation.

All displays of data are in the form of a six-digit LED display capable of showing one item of operating data continuously during normal operation. As a supplement to the display, there are three indicator lamps for indication of mains connection (ON), warning (WARNING) and alarm (ALARM). Most of the frequency converter's parameter Setups can be changed immediately via the control panel, unless this function has been programmed as Locked [1] via parameter 018 *Lock for data changes*.

• Control keys

[QUICK MENU] allows access to the parameters used for the Quick menu.

The **[QUICK MENU]** key is also used if a change to a parameter value is not to be implemented. See also **[QUICK MENU] + [+]**.

[CHANGE DATA] is used for changing a setting. The **[CHANGE DATA]** key is also used for confirming a change of parameter settings.

[+] / [-] are used for selecting parameters and for changing parameter values.

These keys are also used in Display mode for selecting the display of an operating value.

The **[QUICK MENU] + [+]** keys must be pressed at the same time to give access to all parameters. See *Menu mode*.

[STOP/RESET] is used for stopping the connected motor or for resetting the frequency converter after a trip.

Can be selected as Active [1] or Not active [0] via parameter 014 Local stop/reset. In Display mode, the display will flash if the stop function is activated.

NB!

If the **[STOP/RESET]** key is set at Not active [0] in parameter 014 Local stop/reset, and there is no stop command via the digital inputs or serial communication, the motor can only be stopped by disconnecting the mains voltage to the frequency converter.

[START] is used for starting the frequency converter. It is always active, but the **[START]** key cannot override a stop command.

Unit Options

0 - 25% fresh air hood

The 0-25% fresh air hood allows to introduce fresh air into the unit.

This is a manual device fitted on the back of the unit, sized for a maximum of 25% of the nominal rooftop air flow.

This option includes for the hood itself, a wire mesh and a slidable damper.

The slidable damper has to be adjusted manually by removing the screws and sliding it off up or down (See following figure).

The amount of fresh air introduced is then permanently fixed.

Figure 21 - 0 - 25% manual fresh air hood

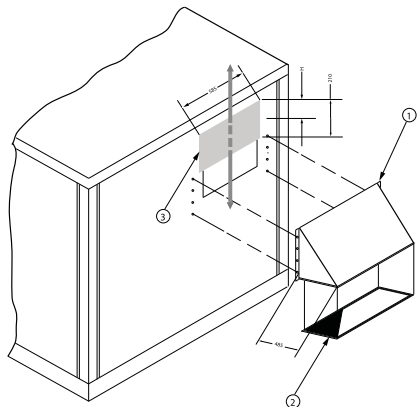

- 1 = Intake hood
- 2 = Wire mesh
- 3 = Slidable damper

Barometric relief

The barometric relief allows to minimize overpressure in the building caused by the introduction of fresh air. This option is typically installed when fresh air intake is below 25% of the nominal air flow and when the return air pressure drop is below 25Pa.

This option includes exhaust hoods and gravity dampers located in the return air section (See next figure).

When the pressure of the building increases the gravity dampers open and release air outside the building.

If the return air duct pressure drop is higher than the building overpressure, the gravity dampers will not open.

If the return air duct pressure drop is lower than the building overpressure, the gravity dampers will open and release air outside of the building.

Energy Recovery Module

The energy Recovery Module option is linked to the fresh air side of the unit and recovers heat from the exhaust air to pre-heat/pre-cool fresh air.

Installation/Operation and maintenance instructions are found in document RT-SVX42.

Figure 22 - Economizer flow chart with barometric relief

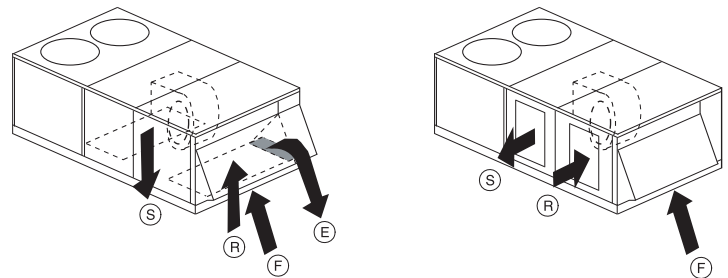

Downflow version

- R = return
- S = supply
- F = fresh air
- E = exhaust

Horizontal flow version

Unit Options

Exhaust fan

This accessory is used to minimize overpressure in the building caused by the introduction of fresh air, when the economizer fresh air damper is set at 40-50% of outdoor air (permanent value), and/or when the pressure drop in the return duct is between the building overpressure accepted by the customer (12-25 Pa) and 200 Pa (maximum fan static pressure).

When the exhaust fans are off, the gravity dampers open with increased building pressure to relieve the air pressure. When the exhaust fans are on, around 50% of airflow can be exhausted, depending on the pressure drop of the return. They turn on whenever the position of the economizer fresh air dampers meet or exceed the power exhaust setpoint (when the supply fan is on).

The setpoint potentiometer is located on the RTOM board (PWX setpoint)

Table 17 - Voyager II Power exhaust fan performances - #125-155-175-200-250-265-290-340

Figure 23 - Power exhaust fan

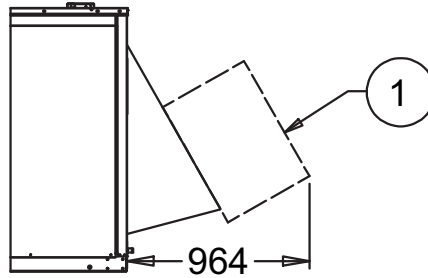

1 = Power exhaust fan

Figure 24 - Power exhaust fan potentiometer on RTOM

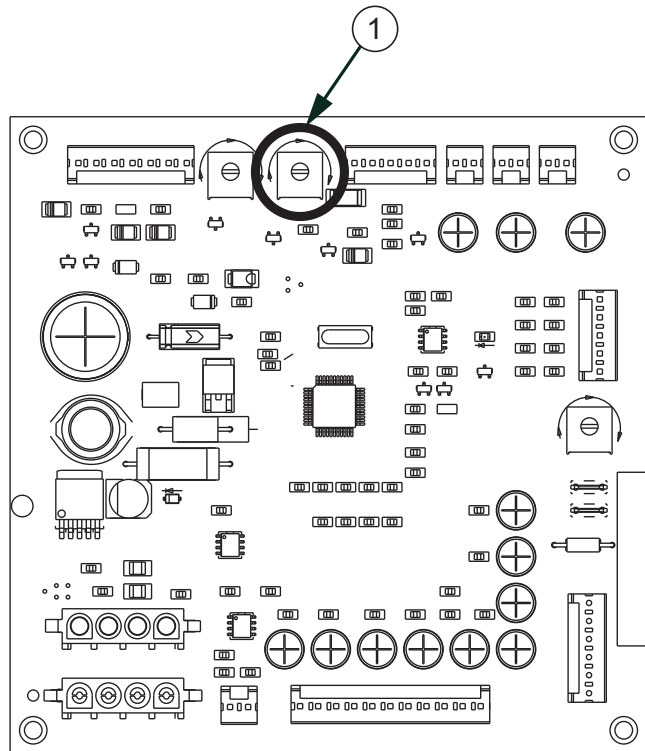

1 = Power exhaust fan potentiometer

Operation with a conventional thermostat

The ReliaTel module has conventional thermostat connections as well as Zone Sensor Module connections. When a conventional thermostat is controlling the unit, operation differs as follows.

- Supply Air Tempering feature is not available. If outdoor air is being introduced through the equipment, discharge air temperature may be cold when not actively heating.
- Proportional Integral (PI) control is not available.
- Zone Sensor Diagnostics are only available on the RTRM module on the J6 terminals, instead of at the Zone Sensor in the space.
- Intelligent Fall-Back is not available. If a failure occurs in the device controlling the equipment, operation will cease.
- Heat Pump Smart Recovery and Smart Staging is not available. Heat Pump operation becomes more costly unless the generic control being applied can accomplish this.
- Remote Sensing Capabilities are not available on most mechanical thermostats.
- Space Temperature Averaging capabilities are not available on most mechanical thermostats.
- 27½ to 50 VAV – Conventional thermostat input terminals are inactive.
- Built in Night Set Back and Unoccupied Functions function differently with a conventional mechanical thermostat.
- A built-in algorithm which allows for automatic reset of the discharge air temperature while economizing is not available.

The terminal strip for attaching the thermostat wires is located on the RTRM module in the control compartment.

The purpose of each terminal is discussed in the next section.

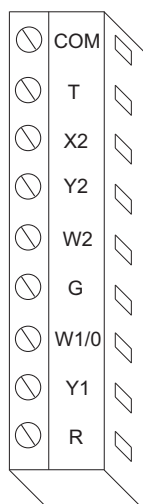

Customers occasionally require operation with a conventional thermostat rather than a zone sensor. In some cases there is a preference for a specific thermostat model, and in others there is reluctance to adopt newer technology that may not be as well understood as conventional thermostats. In addition, non-Trane Building Controllers typically provide an interface to HVAC equipment based on a conventional thermostat interface. Units applied with this type of controller need to accept conventional thermostat inputs.

Conventional thermostat signals represent direct calls for unit functions. In their simplest applications, thermostat contacts directly control contactors or other load switching devices. This function provides inputs for the thermostat signals and processing to enhance reliability and performance. Compressor protection and reliability enhancement functions (HPC, LPC, Minimum On/Off timers, etc.). All operate the same whether applied with zone sensors or a conventional thermostat.

Logic is also provided to cause appropriate unit functions when inappropriate thermostat signals are provided. Simultaneous calls for heating and cooling will be ignored, and the fan will be turned on with a call for heating or cooling even if the fan request is not detected. If the thermostat is immediately changed from a heating to a cooling call, or vice versa, there will be a five minute delay before the new call will initiate.

Thermostat signals are as follows:

R 24VAC power to thermostat

Y1 Call for compressor 1 or first stage cooling

Y2 Call for compressor 2 or 2nd stage cooling

G Call for supply fan

W1 Call for heat 1

W2 Call for heat 2

Heat pump only:

X2 Call for emergency heat

O Switchover valve On = cooling, Off = heating

T Bias for heat anticipation for those mechanical thermostats that use this function

Conventional thermostat –

Gas/ Electric, Electric Heat:

Input/connection	Function when energized :
G (fan)	Fan runs continuously except during unoccupied mode (see next page)
Y1 (compressor 1 or economizer)	Compressor #1 runs or economizer operates
Y2 (compressor 2 or compressor 1 while economizing)	Compressor #2 also runs, or #1 compressor runs while economizing
W1 (gas / electric heat first stage)	1st stage heat
W2 (gas / electric heat 2nd stage)	2nd stage heat (if available)



Operation

Conventional thermostat – Heat Pump

Input/connection	Function when energized
Cooling mode:	
G (fan)	Fan runs continuously except during unoccupied mode (see next page)
O (reversing valve during cooling)	Reversing valve in cool mode
Y1 + O (first stage cooling)	Compressor #1 runs or economizer operates
Y1 + Y2 + O (2nd stage cool)	Compressor #2 also runs, or #1 compressor runs while economizing.
Heating mode:	
G (fan)	Fan runs continuously except during unoccupied mode (see below)
Y1 (both compressors 1st stage heat)	Both compressors run
Y2 (during heating – nothing happens)	No change
W2 (electric heat 2nd stage)	2nd stage (electric) heat
X2 (electric heat only)	Electric heat only – no compressors

T (provides heat anticipation signal for those mechanical thermostats that use this feature. If the thermostat used does not have a “T” terminal, disregard this terminal.

Unoccupied mode:

If the thermostat being used is programmable, it will have its own strategy for unoccupied mode and will control the unit directly. If a mechanical thermostat is being used, a field applied time clock with relay contacts connected to J6-11 and J6-12 can initiate an unoccupied mode as follows:

- Contacts open: Normal occupied operation.
- Contacts closed: Unoccupied operation as follows - Fan in auto mode regardless of fan switch position. Economizer closes except while economizing regardless of minimum position setting.

Cooling/Economizer Operation:

If unit does not have an economizer, the Cool/Econ Stage 1 and Stage 2 will call directly for mechanical cooling (compressor) stages. If the unit has an economizer, the Cool/Econ stages will function as follows.

Table 18 - Cooling/Economizer Operation with Thermostat 1,2

OK to Economize?	Thermostat Y1	Thermostat Y2	Call for Economizer Cooling	Compressor Staging Request
No	On	Off	Inactive	Compressor Output 1
No	Off	On	Inactive	Compressor Output 2
No	On	On	Inactive	Compressor Outputs 1 & 2
Yes	On	Off	Active	Off
Yes	Off	On	Active	Compressor off
Yes	On	On	Active	Compressor

Setting the economizer or 0-50% motorized hood (option)

The RTEM board is mounted on the damper actuator. To access the RTEM board on economizers:

- Remove the access panel located on the economizer section.
- The electrical power must be disconnected to set the minimum position and check the economizer.
- Disconnect the power supply, put the thermostat fan selector to "ON" and the "HEAT/COOL" selector to "OFF". This puts the damper in the minimum ventilation position.
- To set the required minimum ventilation air position, turn the dial on the RTEM clockwise to increase ventilation, or anti-clockwise to decrease ventilation. The damper will open at this setting whenever the fan circuit is powered up.
- When the arrow on the dial adjustment screw is pointing to 8 o'clock, the minimum position is roughly 0%. When the dial is pointing to 12 o'clock it is roughly 25%, and when the dial is pointing to 4 o'clock it is roughly 50%

To check the damper is functioning correctly, the RTEM is equipped with an indicator light in the middle of the board. This light operates as in the following table.

Table 19 - RTEM board LED

OFF:	No Power or Failure
ON:	Normal, OK to Economize
Slow Flash:	Normal, Not OK to Economize
Fast Flash:	Communications Failure
Pulse Flash:	Error Code:
1 Flash:	Actuator Fault
2 Flashes:	CO2 Sensor
3 Flashes:	RA Humidity Sensor
4 Flashes:	RATemp Sensor
5 Flashes:	OA Quality Sensor
6 Flashes:	OA Humidity Sensor
7 Flashes:	OATemp Sensor
8 Flashes:	MATemp Sensor
9 Flashes:	RAM Fault
10 Flashes:	ROM Fault
11 Flashes:	EEPROM Fault

While setting the minimum position the damper may move toward the new setting in several small steps. Once the damper has remained in the same position for 10 to 15 seconds it can be assumed it is in the new position.

Figure 25 - Minimum fresh air adjustment

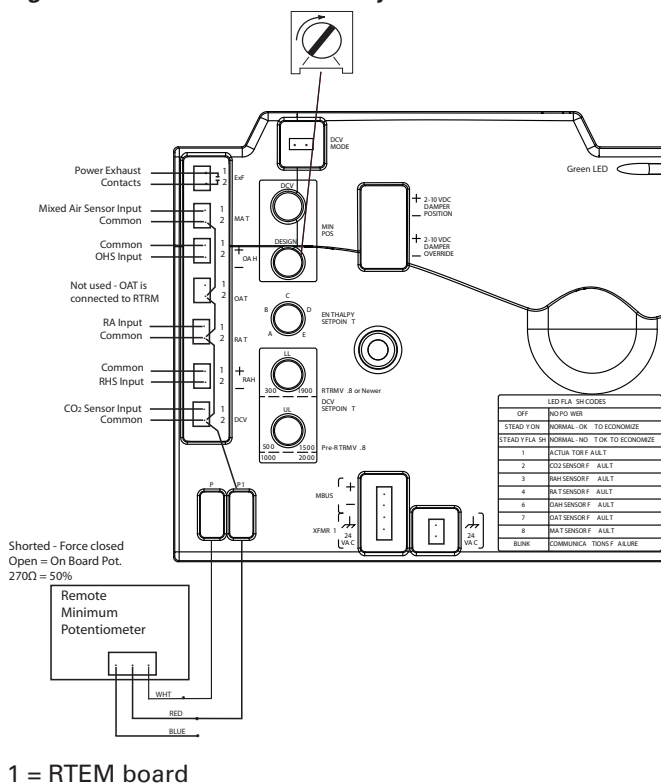



Operation

Test procedures

Operating checklist before start-up

- Unit is level, with sufficient clearance all round
- Duct network is correctly sized according to the unit configuration, insulated, and water-tight
- Condensate drainage line is correctly sized, equipped with a trap, and sloped
- Filters are in position, of correct size and quantity and clean
- Wiring is correctly sized and connected in accordance with wiring diagrams
- Power supply lines are protected by recommended fuses and correctly earthed
- Thermostat is correctly wired and positioned
- Unit is checked for refrigerant charge and leaks
- Indoor and outdoor fans rotate freely and are fixed on shafts
- Supply fan rotation speed is set
- Access panels and doors are replaced to prevent air entering and risks of injury
- Checking of the gas heating section, in accordance with above procedure

WARNING! If any operating checks must be performed with the unit operating, it is the technician's responsibility to recognize any possible hazards and proceed in a safe manner. Failure to do so could result in severe personal injury or death due to electrical shock or contact with moving parts.

Power-up initialization

CAUTION! Before proceeding with any test procedure or operation, make sure that crankcase heaters have been energized for at least 8 hours.

Units equipped with Scroll compressors do not have crankcase heaters.

Note:

Upon power initialization, the RTRM performs self-diagnostic checks to insure that all internal controls are functional. It also checks the configuration parameters against the components connected to the system. The Liteport LED located on the RTRM module is turned "On" within 1 second of power-up if internal operation is okay.

Test mode procedure at the ReliaTel™ control board

Operating the unit from the roof using the test mode at the ReliaTel™ control board.

CAUTION! Before proceeding with the following test procedures, make sure that thermostat or zone sensor is off.

CAUTION! Use one of the following "Test" procedures to bypass some time delays and to start the unit at the control panel.

Each step of unit operation can be activated individually by temporarily shorting across the "Test" terminals for two to three seconds. The Liteport LED located on the RTRM module will blink when the test mode has been initiated. The unit can be left in any "Test" step for up to one hour before it will automatically terminate, or it can be terminated by opening the main power disconnect switch. Once the test mode has been terminated, the Liteport LED will glow continuously and the unit will revert to the "System" control.

Test modes

There are 2 methods in which the “Test” mode can be cycled with the test button:

1. Step Test Mode

This method initiates the different components of the unit, one at a time, by temporarily shorting across the two test terminals for two to three seconds. For the initial start-up of the unit, this method allows the technician to cycle a component “On” and have up to 1 hour to complete the check.

2. Auto Test Mode

This method is not recommended for start-up due to the short timing between individual component steps. This method initiates the different components of the unit, one at a time, when a jumper is installed across the test terminals. The unit will start the first test step and change to the next step every 30 seconds. At the end of the test mode, control of the unit will automatically revert to the applied “System” control method.

For unit test steps and test modes, values to cycle the various components, refer to the following table.

Table 20 - Service Test Guide for Component Operation on gas-fired units

TK* / YK*

Step	Mode	Comp 1	Comp 2	Outdoor Fan1	Outdoor Fan2	HEAT 1	HEAT 2	SOV	Economizer	Exhaust Fan	Indoor Fan
1	FAN	Off	Off	Off	Off	Off	Off	-	Min.	(2)	ON
2	Econ.	Off	Off	Off	Off	Off	Off	-	100%	(2)	ON
3	COOL1	ON	Off	ON	ON (1)	Off	Off	-	Min.	(2)	ON
4	COOL2	ON	ON	ON	ON (1)	Off	Off	-	Min.	(2)	ON
5	HEAT1	Off	Off	Off	Off	On	Off	-	Min.	(2)	ON
6	HEAT2	Off	Off	Off	Off	ON	ON	-	Min.	(2)	ON

WK* / DK*

Step	Mode	Comp 1	Comp 2	Outdoor Fan1	Outdoor Fan2	HEAT 1	HEAT 2	SOV	Economizer	Exhaust Fan	Indoor Fan
1	FAN	Off	Off	Off	Off	Off	Off	ON	Min.	(2)	ON
2	Econ.	Off	Off	Off	Off	Off	Off	ON	100%	(2)	ON
3	COOL1	ON	Off	ON	ON (1)	Off	Off	ON	Min.	(2)	ON
4	COOL2	ON	ON	ON	ON (1)	Off	Off	ON	Min.	(2)	ON
5	HEAT1 (3)	ON	Off	ON	Off	Off	Off	-	Min.	(2)	ON
6	HEAT2	ON	ON	ON	ON	ON	Off	-	Min.	(2)	ON
7	HEAT3	ON	ON	ON	ON	ON	ON	-	Min.	(2)	ON
8	HEAT4	ON	ON	ON	ON	ON	ON	-	Min.	(2)	ON
9	Defrost	ON	ON	Off	Off	ON	Off	ON	Min.	(2)	ON
10	Emerg. Heat	Off	Off	Off	Off	ON	ON	-	Min.	(2)	ON

Notes:

1. Outdoor fan is controlled according to compressor status and outdoor temperature
2. Exhaust fan switches ON when fresh air damper position exceeds EXF setpoint defined on RTOM
- 3, Sizes 290-340 only

Operation

Unit start-up

Verification of gas valve settings - (Reserved for the qualified gas technician)

WARNING! Improper gas valve setting may lead to burner destruction and people injury.

Note: Unit factory-set for G20.

Note: Unit to be installed outside only.

Note: Expansion valve must be adapted to the type of gas used:

- G 20: 20 mb
- G 25: 25 mb
- G 31 (Propane): 37 or 50 mb

Figure 26 - Gas valve

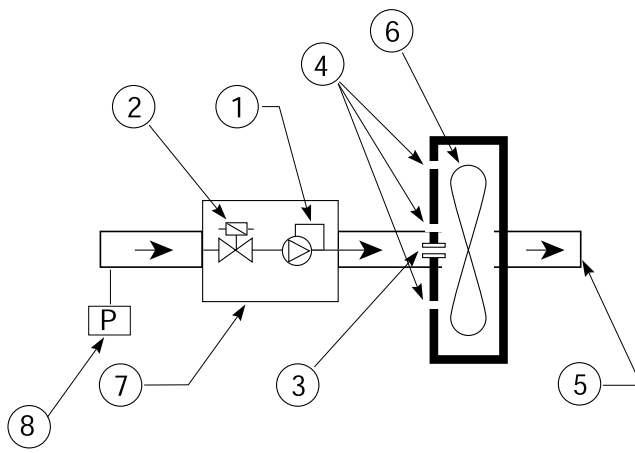

- 1 = Negative pressure controller
- 2 = Safety solenoid valve
- 3 = Gas injector
- 4 = Air inlets
- 5 = To the burner
- 6 = Fan
- 7 = Gas unit
- 8 = Minimum gas pressure cut-out

Table 21 - EU Gas categories for Trane rooftop gas burners

CAT		G20	G25	G31
II2E+3P			FR	
	mbar	20	25	37
II2H3P			CH - CZ - ES - GB - GR - IE - PT	
	mbar	20	-	37
II2H3+			IT	
	mbar	20	-	28-30 / 37
II2L3P			NL	
	mbar		25	30
I2E+			BE	
	mbar	20	25	-
I2E			DE - LU - PL	
	mbar	20	-	-
I2H			AT - DK - EE - FI - LT - LV - NO - SE - SI - SK - TR	
	mbar	20	-	-
			HU	
I3P			BE - CZ - PL - SI - SK - TR	
	mbar	-	-	37
			AT - DE - HU - LU - SK	
	mbar	-	-	50

AT	Austria
BE	Belgium
CH	Switzerland
CZ	Czech Republic
DE	Germany
DE	Germany
DK	Denmark
EE	Estonia
EE	Estonia
ES	Spain
FI	Finland
FR	France
GB	Great Britain (UK)
GR	Greece

HU	Hungary
HU	Hungary
IE	Ireland
IT	Italy
LT	Lithuania
LU	Luxembourg
LV	Latvia
NL	Netherlands
NO	Norway
PL	Poland
PT	Portugal
SE	Sweden
SI	Slovenia
SK	Slovakia (Slovak Republic)
TR	Turkey



Operation

Table 22 - Hot water coil and gas burner data

Gas Burner		G250	G350	G400	
YK* 155-175-200-250			1		
DK* 125		1			
DK* 155-200-265			1		
DK* 290-340				1	
Burner		G250	G350	G400	
Natural Gas G20 (20mbar) 34.02 MJ/m³ (15°C-1013)					
Gas Flow (15 C-1013 mbar)	(m ³ /h)	Nominal rate	5.6	8.1	9
		Reduced rate	5.08	8.13	8.47
Heating Capacity	(kW)	Nominal rate	48.2	69.3	77.4
		Reduced rate	43.7	69.1	72.8
Heating Rate	(kW)	Nominal rate	53	77	85
		Reduced rate	48	76.8	80
Efficiency	%	Nominal rate	90.9	90.0	91.1
		Reduced rate	91	90	91
Smoke analysis	G20 - 20mbar @ 400V-3-50Hz	CO %	< 0.001%	< 0.001%	< 0.001%
		Nox ppm	19 ppm	9 ppm	46 ppm
		CO ₂ %	8.5%	9.7%	9.6%
Burner		G250	G350	G400	
Natural Gas G25 (20 or 25 mbar) 29.30 MJ/m³ (15°C-1013)					
Gas Flow (15 C-1013 mbar)	(m ³ /h)	Nominal rate	5.3	8.2	8.8
		Reduced rate	5.15	8.02	8.21
Heating Capacity	(kW)	Nominal rate	38.3	60.3	62.9
		Reduced rate	37.5	58.5	59.5
Heating Rate	(kW)	Nominal rate	43	67	71.5
		Reduced rate	41.9	65.3	66.8
Efficiency	%	Nominal rate	89	90	88
		Reduced rate	89	90	89
Smoke analysis	G25 - 25mbar @ 400V-3-50Hz	CO %	0.050%	< 0.001%	< 0.001%
		Nox ppm	-	-	-
		CO ₂ %	7.1%	7.0%	7.4%
Burner		G250	G350	G400	
Propane Gas G31 (30, 37 or 50 mbar) 88.00 MJ/m³ (15 C-1013)					
Gas Flow (15 C-1013 mbar)	(m ³ /h)	Nominal rate	2.2	2.7	3.5
		Reduced rate	2.17	2.56	3.19
Gas Flow (15 C-1013 mbar)	(kg/h)	Nominal rate	4.2	5.1	6.6
		Reduced rate	4.1	4.9	6.1
Heating Capacity	(kW)	Nominal rate	48.6	57.5	78.2
		Reduced rate	47.7	55.3	71.8
Heating Rate	(kW)	Nominal rate	54	65.3	85
		Reduced rate	53	62.6	78
Efficiency	%	Nominal rate	90	88	92
		Reduced rate	90	88.3	92
Combustion Air Flow (With E=25%)	(m ³ /h)	Nominal rate	72	98	113
		Reduced rate	71	93	103
Smoke analysis	G31 - 37mbar @ 400V-3-50Hz	CO %	< 0.001%	< 0.001%	0.002%
		Nox ppm	-	-	-
		CO ₂ %	9.3%	8.9%	12.0%

Hot Water coil	
UNIT	Water connection inlet/outlet (inches)
TKD 155-175-200-250-265-290-340	1 ¼ ISO R7
WKD 125-155-200-265-290-340	

Starting the unit in cooling mode

Before start-up, ensure that all power cables are tightened.

Verify that the unit airflow rate is adjusted according to the information provided in the "Supply fan adjustment" section of this manual.

To start the unit in cooling mode:

- Place the zone sensor system switch in the "COOL" position.
- Position the cooling setpoint approximately 10° below room temperature and place the fan switch in the "AUTO" or "ON" position.
- Turn on unit main power supply.

The condenser fan motor, compressor and supply fan motor should operate automatically.

There will be a delay of up to 5 minutes before the unit starts in cooling mode.

Operating pressures

After the unit has operated in cooling mode for a short period of time, install pressure gauges on the gauge ports of the discharge and suction line valves.

Note: To bypass time delays and verify the operation of this unit from the roof, use the "Test procedure" section in this manual. Check the suction and discharge pressures.

Note: Always route refrigerant hoses through the port hole provided and ensure that the compressor access panel is in place.

Cooling shutdown

To exit the test mode, disconnect unit power for 3-5 seconds and reapply. When running the unit using the zone sensor as the control, position the selector switch to "OFF".

There may be a delay of up to 3 minutes before compressors shut down and an additional one minute before the fan shuts down in this setting.

Do not de-energize main power disconnect except when unit is to be serviced. Power is required to keep the compressor crankcase warm and boil off refrigerant in the oil (except on units with Scroll compressors).

Final installation checklist

- Are all power cables tightened?
Check torque of power cables contact !
- Is the condenser fan and indoor blower operating correctly, i.e. correct rotation and without undue noise?
- Are the compressors operating correctly and has the system been checked for leaks?
- Have the voltage and running currents been checked to determine if they are within limits?
- Have the air discharge grilles been adjusted to balance the system?
- Has the ductwork been checked for air leaks and any condensation?
- Has the air temperature rise been checked?
- Has the indoor airflow been checked and adjusted if necessary?
- Has the unit been checked for tubing and sheet metal rattles or any unusual noises?
- Are all covers and panels in place and properly fastened?

ReliaTel™ is a microelectronic control feature, which provides operating functions that are significantly different from conventional electro-mechanical units. The master module is the ReliaTel™ Refrigeration Module (RTRM).

The RTRM provides compressor antishort cycle timing functions through minimum "Off" and "On" timing to increase reliability, performance and to maximize unit efficiency.

Upon power initialization, the RTRM performs self-diagnostic checks to insure that all internal controls are functioning. It checks the configuration parameters against the components connected to the system.

The LED located on the RTRM module is turned "On" within one second after power-up if all internal operations are okay.



Operation

Cooling without an Economizer

When the system switch is set to the “Cool” position and the zone temperature rises above the cooling setpoint controlband, the RTRM energizes the (K9) relay coil located on the RTRM. When the K9 relay contacts close, the compressor contactor (CC1) coil is energized provided the low pressure control (LPC1) and high pressure control (HPC1) are closed. When the CC1 contacts close, compressor (CPR1) and the outdoor fan motor (ODM) start to maintain the zone temperature to within ± 2 F of the sensor setpoint at the sensed location.

If the first stage of cooling can not satisfy the cooling requirement, the RTRM energizes the (K10) relay coil located on the RTRM. When the (K10) relay contacts close, the compressor contactor (CC2) coil is energized provided the low pressure control (LPC2) and high pressure control (HPC2) are closed. When the CC2 contacts close, compressor (CPR2) starts to maintain the zone temperature to within ± 2 F of the sensor setpoint at the sensed location.

Evaporator Fan Operation

When the fan selection switch is set to the “Auto” position, the RTRM energizes the (K6) relay coil approximately one second after energizing the compressor contactor coil (CC1) in the cooling mode. In heating mode, the RTRM energizes the (K6) relay coil approximately 45 seconds after gas ignition. Closing the K6 contacts on the RTRM energizes the supply fan relay (F) coil to start the supply fan motor (IDM).

The RTRM de-energizes the fan relay (F) approximately 60 seconds after the cooling requirement has been satisfied to enhance unit efficiency.

When the heating cycle is terminated, the supply fan relay (F) coil is de-energized approximately 90 seconds after the heating requirement.

When the fan selection switch is set to the “On” position, the RTRM keeps the supply fan relay coil (F) energized for continuous fan motor operation.

When the unit is equipped with the optional clogged filter switch, wired between terminals J7-3 and J7-4 on the ReliaTel™ Options Module (RTOM), the RTRM produces an analog output if the clogged filter switch (CFS) closes for two minutes after a request for fan operation. When the system is connected to a remote panel, the “SERVICE” LED will be turned on when this failure occurs.

Low Ambient Operation

During low ambient operation, outside air temperature below 13°C, the RTRM will cycle the compressor and outdoor fan motor “Off” for approximately three minutes after every 10 minutes of accumulated compressor run time. The supply fan motor (IDM) will continue to operate during this evaporator defrost cycle (EDC) and the compressor and outdoor fan will return to normal operation once the defrost cycle has terminated and the compressor “Off” time delay has been satisfied.

Cooling with an Economizer

The economizer is utilized to control the zone temperature providing the outside air conditions are suitable.

Outside air is drawn into the unit through modulating dampers. When cooling is required and economizing is possible, the RTRM sends the cooling request to the unit economizer actuator (ECA) to open the economizer damper. The RTRM tries to cool the zone utilizing the economizer to slightly below the zone temperature setpoint. If the mixed air sensor (MAS) senses that the mixed air temperature is below 53°F, the damper modulates toward the closed position. If the zone temperature continues to rise above the zone temperature setpoint controlband and the economizer damper is full open, the RTRM energizes the compressor contactor (CC1). If the zone temperature continues to rise above the zone temperature setpoint controlband and the economizer damper is fully open, the RTRM energizes the compressor contactor (CC2).

The RTRM continues to modulate the economizer damper open/closed to keep the mixed air temperature that is calculated by the RTRM.

If economizing is not possible, the RTRM drives the damper to the minimum position setpoint when the supply fan relay (F) is energized and allows mechanical cooling operation. When the unit is equipped with the optional fan failure switch, wired between terminals J7-5 and J7-6 on the RTOM, the RTRM will stop all cooling functions and produce an analog output if the fan failure switch (FFS) does not open within 40 seconds after a request for fan operation. When the system is connected to a remote panel, the “SERVICE” LED will flash when this failure occurs.

Economizer Set-Up

Adjusting the minimum position potentiometer located on the unit economizer Actuator (ECA) sets the required amount of ventilation air.

Two of the three methods for determining the suitability of the outside air can be selected utilizing the enthalpy potentiometer on the RTEM, as described below:

1. Ambient Temperature - controlling the economizing cycle by sensing the outside air dry bulb temperature. The Table below lists the selectable dry bulb values by potentiometer setting.
2. Reference Enthalpy - controlling the economizer cycle by sensing the outdoor air humidity. The Table below lists the selectable enthalpy values by potentiometer setting.
If the outside air enthalpy value is less than the selected value, the economizer is allowed to operate.
3. Comparative Enthalpy - By utilizing a humidity sensor and a temperature sensor in both the return air stream and the outdoor air stream, the unit control processor (RTRM) will be able to establish which conditions are best suited for maintaining the zone temperature, i.e. indoor conditions or outdoor conditions.
The potentiometer located on the RTEM is non-functional when both the temperature and humidity sensors are installed.

Table 23 - Potentiometer Setting

Potentiometer Setting	Dry Bulb (°C)	Enthalpy (KJ/kg)
A	23*	63
B	21	58
C	19	53
D	17	51

*Factory Setting

ReliaTel™ Control Heating Operation

When the system switch is set to the "Heat" position and the zone temperature falls below the heating setpoint controlband, a heat cycle is initiated when the RTRM communicates ignition information to the Ignition module (IGN).

Ignition Module

Two Stage (IGN) runs self-check (including verification that the gas valve is de-energized). (IGN) checks the high-limit switches (TC01 & TC02) for normally closed contacts. With 115 VAC power supplied to the ignition module (IGN), the hot surface ignition probe (IP) is preheated for approximately 45 seconds. The gas valve (GV) is energized for approximately 7 seconds for trial for ignition, to ignite the burner.

Once the burner is ignited, the hot surface ignition probe (IP) is de-energized by the ignition module (IGN) and functions as the flame sensing device.

If the burner fails to ignite, the ignition module will make two more attempts before locking out. The green LED will indicate a lock out by two fast flashes. An ignition lockout can be reset by:

1. Opening for 3 seconds and closing the main power disconnect switch
2. By switching the "Mode" switch on the zone sensor to "OFF" and then to the desired position
3. Allowing the ignition control module to reset automatically after one hour.

Refer to the ignition control module diagnostics section for the LED diagnostic definitions.

When the fan selection switch is set to the "Auto" position, the RTRM energizes the supply fan relay (F) coil approximately 30 second after initiating the heating cycle to start the supply fan motor (IDM).

The automatic reset high limit (TCO1), located in the bottom right corner of the burner compartment, protects against abnormally high leaving air temperatures.

The automatic reset fan fail limit (TCO2), located in the upper middle section of the supply fan board, protects against abnormally high heat buildup which could occur because of extended cycling of the high limit (TCO1) or if the supply fan motor (IDM) fails to operate. Should TCO2 open, the RTRM will energize the supply fan relay (F) in an attempt to start the fan motor. The RTRM signals that a heat failure has occurred by flashing the "Heat" LED on the zone sensor.

There is a Green LED located in the Ignition Control Module. The table below lists the diagnostics and the status of the LED during the various operating states.



Operation

Final installation checklist

- Is the condenser fan and indoor blower operating correctly, i.e.: correct rotation and without undue noise?
- Are the compressors operating correctly and has the system charge been checked?
- Has the gas module been installed as per the procedure in this manual?
- Have the voltage and running currents been checked to determine if they are within limits?
- Have the air discharge grilles been adjusted to balance the system?
- Has the ductwork been checked for air leaks and any condensation?
- Has the heating air temperature rise been checked?
- Has the indoor airflow been checked and adjusted if necessary?
- Has the unit been checked for tubing and sheet metal rattles or any unusual noises?
- Are all covers and panels in place and properly fastened?

To keep the unit operating safely and efficiently, the manufacturer recommends that a qualified service technician check the entire system at least once each year, or more frequently if conditions warrant.

Table 24 -LED status

Diagnostics	Green LED	Red LED
1. Powered but no heat demand	Off	Off
2. Heat demand without fault	Flashing	Off
3. No flame detection on ignition - or signal detected and then lost	Off	Flashing
4. Gas unit incorrectly wired or flame signal detected on a heat demand	Steady	Flashing
5. Internal fault	Off	Steady

Maintenance

To keep the unit operating safely and efficiently, the manufacturer recommends that a qualified service technician check the entire system at least once each year, or more frequently if conditions warrant it.

End user routine maintenance

Some of the periodic maintenance functions for the unit can be undertaken by the end user. This includes replacing (disposable) or cleaning (permanent) air filters, cleaning unit cabinet, cleaning the condenser coil, and carrying out a general unit inspection on a regular basis.

WARNING! Disconnect the power supply before removing access panels to service the unit. Failure to disconnect power before attempting any servicing can result in severe injury or death.

Air filters

It is very important for the central duct system air filters to be kept clean.

These should be inspected at least once a month when the system is in constant operation (in new buildings, the filters should be checked every week for the first four weeks). If disposable-type filters are used, they should only be replaced with ones of the same type and size.

Supply Fan Drive

Belt drive sheaves alignment has to be checked during each maintenance inspection.

Check belt tension. Refer to table 6b

Direct drive fan

Direct drive fan/motor assembly is mounted in factory with a perfect adjustment of the motor position. If for any reason, the motor or the fan has been moved, a new alignment of the motor and fan shaft must be done. Please contact your local Trane representative for alignment procedure.

Refer to Figure 29 for Motor/fan shaft alignment tolerances.

Figure 27 - Motor/fan shaft alignment tolerances

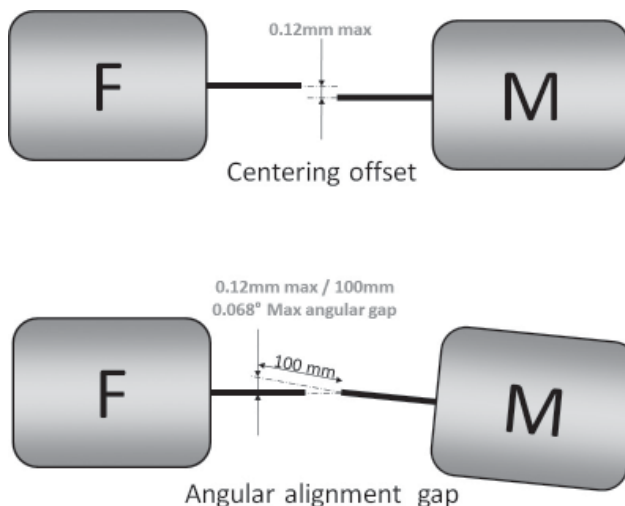

Note: Do not attempt to clean disposable filters.

Permanent filters can be cleaned by washing with a mild detergent and water. Ensure that the filters are thoroughly dry before reinstalling them in the unit (or duct system).

Note: Replace permanent filters annually if washing fails to clean them, or they show signs of deterioration. Be sure to use the same type and size as were originally installed.

Condenser coil

Unfiltered air circulates through the unit's condenser coil and can cause the coil's surface to become clogged with dust, dirt, etc. To clean the coil, brush the coil surface in the direction of the fins with a soft bristled brush.

Keep all vegetation away from the condenser coil area.

Hot water coil (option)

Stop the unit. Do not disconnect the main supply to the unit. This will permit the anti-frost protection to continue to operate, and avoid water to freeze-up in the coil.

Service technician maintenance

Before the cooling season, your service technician may examine the following areas of your unit:

- Filters, for cleaning or replacement
- Motors and drives system components
- Economizer gaskets, for replacement if necessary
- Condenser coils, for cleaning
- Safety controls, for mechanical cleaning
- Electrical components and wiring, for replacement and tightening of connections as necessary
- Condensate drain, for cleaning
- Unit duct connections, to ensure they are physically sound and sealed to the unit casing
- Unit mounting support, to ensure that it is sound
- The unit, to ensure there is no obvious deterioration

Before the heating season, your service technician may examine the following areas of your unit:

- The unit, to ensure that the condenser coil can receive the required airflow (that the condenser fan grille is not obstructed)
- The control panel wiring, to verify that all electrical connections are tight, and that wire insulation is intact
- Clean burner area, verify the gas heat system operates properly.

Maintenance

Troubleshooting

The RTRM has the ability to provide the service personnel with some unit diagnostics and system status information. Before turning the main power disconnect switch "Off" follow the steps below to check the ReliaTel™

Refrigeration Module (RTRM). All diagnostics & system status information stored in the RTRM will be lost when the main power is turned "Off".

1. Verify that the Liteport LED on the RTRM is burning continuously. If the LED is lit, go to Step 3.
2. If the LED is not lit, verify that 24 VAC is present between J1-1 and J1-2. If 24 VAC is present, proceed to Step 3. If 24 VAC is not present, check the unit main power supply, check transformer (TNS1). Proceed to Step 3 if necessary.
3. Utilizing "Method 1" or "Method 2" in the system status diagnostic section, check the following: System status, Heating status, Cooling status. If a System failure is indicated, proceed to Step 4. If no failures are indicated, proceed to Step 5.
4. If a System failure is indicated, recheck Steps 1 and 2. If the LED is not lit in Step 1, and 24 VAC is present in Step 2, the RTRM has failed. Replace the RTRM.
5. If no failures are indicated, use one of the TEST mode procedures described in the unit "Start-Up" section to start the unit. This procedure will allow you to check all of the RTRM outputs, and all of the external controls (relays, contactors, etc.) that the RTRM outputs energize, for each respective mode. Proceed to Step 6.
6. Step the system through all of the available modes, and verify operation of all outputs, controls, and modes. If a problem in operation is noted in any mode, you may leave the system in that mode for up to one hour while troubleshooting. Refer to the sequence of operations for each mode, to assist in verifying proper operation. Make the necessary repairs and proceed to Steps 7 and 8.
7. If no abnormal operating conditions appear in the test mode, exit the test mode by turning the power "Off" at the main power disconnect switch.
8. Refer to the individual component test procedures if other microelectronic components are suspect.

System Status Checkout Procedure

"System Status" is checked by using one of the following two methods:

Method 1

If the Zone Sensor Module (ZSM) is equipped with a remote panel with LED status indication, you can check the unit within the space. If the ZSM does not have LED's, use Method 2.

THS/P03 have the remote panel indication feature. The LED descriptions are listed below:

LED 1 (System) "On" during normal operation. "Off" if a system failure occurs or the LED fails. "Flashing" indicates test mode.

LED 2 (Heat) "On" when the heat cycle is operating. "Off" when the heat cycle terminates or the LED fails. "Flashing" indicates a heating failure.

LED 3 (Cool) "On" when the cooling cycle is operating. "Off" when the cooling cycle terminates or the LED fails. "Flashing" indicates a cooling failure.

LED 4 (Service) "On" indicates a clogged filter. "Off" during normal operation. "Flashing" indicates an supply fan failure.

Below is the complete listing of failure indication causes:

System failure

Check the voltage between terminals 6 and 9 on J6, it should read approximately 32 VDC. If no voltage is present, a system failure has occurred. Refer to Step 4 in the previous section for the recommended troubleshooting procedure.

Heating Failure

Verify Heat Failure by Ignition Module (IGN) LED indicator:

OFF: No Power or Failure

ON: Normal

Slow Flash: Normal, Heat Call

Fast Flash: Error Code:

1 Flash: Communication Failure

2 Flashes: System Lockout

3 Flashes: Pressure Switch Fail

4 Flashes TC01 or TC02 Open

5 Flashes: Flame w/o Gas Valve

6 Flashes: Flame Rollout Open

Maintenance

Cooling Failure

1. Cooling and heating set point (slide pot) on the zone sensor has failed. Refer to the "Zone Sensor Test Procedure" section.
2. Zone temperature thermistor ZTEMP on ZTS failed. Refer to the "Zone Sensor Test Procedure" section.
3. CC1 or CC2 24 VAC control circuit has opened, check CC1 & CC2 coils, and any of the controls below that apply to the unit (HPC1, HPC2).
4. LPC1 has opened during the 3 minute minimum "on time" during 4 consecutive compressor starts, check LPC1 or LPC2 by testing voltage between the J1-8 & J3-2 terminals on the RTRM and ground. If 24 VAC is present, the LPC's has not tripped. If no voltage is present, LPC's has tripped.

Service Failure

1. If the supply fan proving switch has closed, the unit will not operate (when connected to RTOM), check the fan motor, belts, and proving switch.
2. Clogged filter switch has closed, check the filters.

Simultaneous Heat and Cool Failure

1. Emergency Stop is activated

Method 2

The second method for determining system status is done by checking voltage readings at the RTRM (J6).

The system indication descriptions and the approximate voltages are listed below.

System Failure

Measure the voltage between terminals J6-9 & J6-6.

Normal Operation = approximately 32 VDC

System Failure = less than 1 VDC, approximately 0.75 VDC

Test Mode = voltage alternates between 32 VDC & 0.75 VDC

Heat Failure

Measure the voltage between terminals J6-7 & J6-6.

Heat Operating = approximately 32 VDC

Heat Off = less than 1 VDC, approximately 0.75 VDC

Heating Failure = voltage alternates between 32 VDC & 0.75 VDC

Cool Failure

Measure the voltage between terminals J6-8 & J6-6.

Cool Operating = approximately 32 VDC

Cool Off = less than 1 VDC, approximately 0.75 VDC

Cooling Failure = voltage alternates between 32 VDC & 0.75 VDC

Service Failure

Measure the voltage between terminals J6-10 & J6-6.

Clogged Filter = Approximately 32 VDC.

Normal = Less than 1 VDC, approximately 0.75 VDC

Fan Failure = voltage alternates between 32 VDC & 0.75 VDC.

To use LED's for quick status information at the unit, purchase a ZSM and connect wires with alligator clamps to terminals 6 through 10.

Connect each respective terminal wire (6 through 10) from the Zone Sensor to the unit J6 terminals 6 through 10.

Note: If the system is equipped with a programmable zone sensor THS03, the LED indicators will not function while the ZSM is connected.

Resetting Cooling and Ignition Lockouts

Cooling Failures and Ignition

Lockouts are reset in an identical manner. Method 1 explains resetting the system from the space, Method 2 explains resetting the system at the unit.

Note: Before resetting Cooling Failures and Ignition Lockouts, check the Failure Status Diagnostics by the methods previously explained.

Diagnostics will be lost when the power to the unit is disconnected.

Method 1

To reset the system from the zone, turn the "Mode" selection switch at the zone sensor to the "Off" position.

After approximately 30 seconds, turn the "Mode" selection switch to the desired mode, i.e. Heat, Cool or Auto.

Method 2

To reset the system at the unit, cycle the unit power by turning the disconnect switch "Off" and then "On".

Lockouts can be cleared through the building management system. Refer to the building management system instructions for more information.

Zone Temperature Sensor (ZTS) Service Indicator

The ZSM SERVICE LED is a generic indicator that will signal the closing of a Normally Open switch at any time, providing the Indoor Motor (IDM) is operating. This indicator is usually used to indicate a clogged filter, or an air side fan failure.

The RTRM will ignore the closing of this Normally Open switch for 2 (± 1) minutes. This helps prevent nuisance SERVICE LED indications. The exception is the LED will flash 40 seconds after the fan is turned "On" if the Fan Proving Switch is not made.



Maintenance

Clogged Filter Switch

This LED will remain lit the entire time that the Normally Open switch is closed. The LED will be turned off immediately after resetting the switch (to the Normally Open position), or any time that the IDM is turned "Off".

If the switch remains closed, and the IDM is turned "On", the SERVICE LED will be turned "On" again after the 2 (± 1) minute ignore delay.

This LED being turned "On", will have no other affect on unit operation. It is an indicator only.

Fan Failure Switch

When the "Fan Failure" switch is wired to the RTOM, the LED will remain flashing the entire time the fan proving switch is closed, indicating a fan failure, and it will shut the unit operations down.

Zone Temperature Sensor (ZTS) Test

Note: These procedures are not for programmable or digital models and are conducted with the Zone Sensor Module electrically removed from the system.

Test 1

Zone Temperature Thermistor (ZTEMP)

This component is tested by measuring the resistance between terminals 1 and 2 on the Zone Temperature Sensor.

Table 25 - Thermistor Resistance / Temperature Chart

Temperature/resistance coefficient is negative.

Temperature (°C)	Resistance (kOhms)
-21	103
-15	74.65
-9	54.66
-7	46.94
-4	40.4
-1	34.85
2	30.18
4	26.22
7	22.85
10	19.96
13	17.47
16	15.33
18	13.49
21	11.89
24	10.5
27	9.297
29	8.247
32	7.33
35	6.528
38	5.824

Maintenance

Table 26 - Refrigerant saturated temperature/pressure

Refrigerant T° sat	R410A P sat relative	Refrigerant T° sat	R410A P sat relative
-20.0 °C	3.0 bar	25.0 °C	15.6 bar
-19.0 °C	3.2 bar	26.0 °C	16.0 bar
-18.0 °C	3.3 bar	27.0 °C	16.5 bar
-17.0 °C	3.5 bar	28.0 °C	16.9 bar
-16.0 °C	3.6 bar	29.0 °C	17.4 bar
-15.0 °C	3.8 bar	30.0 °C	17.9 bar
-14.0 °C	4.0 bar	31.0 °C	18.4 bar
-13.0 °C	4.2 bar	32.0 °C	18.9 bar
-12.0 °C	4.4 bar	33.0 °C	19.4 bar
-11.0 °C	4.6 bar	34.0 °C	19.9 bar
-10.0 °C	4.7 bar	35.0 °C	20.5 bar
-9.0 °C	4.9 bar	36.0 °C	21.0 bar
-8.0 °C	5.2 bar	37.0 °C	21.5 bar
-7.0 °C	5.4 bar	38.0 °C	22.1 bar
-6.0 °C	5.6 bar	39.0 °C	22.7 bar
-5.0 °C	5.8 bar	40.0 °C	23.3 bar
-4.0 °C	6.0 bar	41.0 °C	23.9 bar
-3.0 °C	6.3 bar	42.0 °C	24.5 bar
-2.0 °C	6.5 bar	43.0 °C	25.1 bar
-1.0 °C	6.8 bar	44.0 °C	25.7 bar
0.0 °C	7.0 bar	45.0 °C	26.3 bar
1.0 °C	7.3 bar	46.0 °C	27.0 bar
2.0 °C	7.5 bar	47.0 °C	27.7 bar
3.0 °C	7.8 bar	48.0 °C	28.3 bar
4.0 °C	8.1 bar	49.0 °C	29.0 bar
5.0 °C	8.4 bar	50.0 °C	29.7 bar
6.0 °C	8.7 bar	51.0 °C	30.4 bar
7.0 °C	9.0 bar	52.0 °C	31.1 bar
8.0 °C	9.3 bar	53.0 °C	31.9 bar
9.0 °C	9.6 bar	54.0 °C	32.6 bar
10.0 °C	9.9 bar	55.0 °C	33.4 bar
11.0 °C	10.2 bar	56.0 °C	34.2 bar
12.0 °C	10.5 bar	57.0 °C	35.0 bar
13.0 °C	10.9 bar	58.0 °C	35.8 bar
14.0 °C	11.2 bar	59.0 °C	36.6 bar
15.0 °C	11.6 bar	60.0 °C	37.4 bar
16.0 °C	11.9 bar	61.0 °C	38.3 bar
17.0 °C	12.3 bar	62.0 °C	39.1 bar
18.0 °C	12.7 bar	63.0 °C	40.0 bar
19.0 °C	13.1 bar	64.0 °C	40.9 bar
20.0 °C	13.5 bar	65.0 °C	41.8 bar
21.0 °C	13.9 bar	66.0 °C	42.8 bar
22.0 °C	14.3 bar	67.0 °C	43.7 bar
23.0 °C	14.7 bar	68.0 °C	44.7 bar
24.0 °C	15.1 bar	69.0 °C	45.7 bar
		70.0 °C	46,7 bar



Notes



Notes



Trane optimizes the performance of homes and buildings around the world. A business of Ingersoll Rand, the leader in creating and sustaining safe, comfortable and energy efficient environments, Trane offers a broad portfolio of advanced controls and HVAC systems, comprehensive building services and parts. For more information visit www.Trane.com

© 2014 Trane All rights reserved
RT-SVX19F-E4 August 2014
Supersedes RT-SVX19E-E4_0213

We are committed to using environmentally
conscious print practices that reduce waste.

